

CONTENTS

1. Introduction	2	5. Ignition System	33	10. Fuel System	47
2. Specifications	3	5.1 Ignition Module	33	10.1 Air Filter	47
2.1 Engine	3	5.1.1 Ignition Timing	34	10.2 Carburetor	48
2.2 Fuel System	3	5.1.2 Removing and Installing	34	10.2.1 Removing and Installing	48
2.3 Ignition System	4	5.2 Spark Plug Boot/ Ignition Lead	35	10.2.2 Leakage Test	49
2.4 Cutting Attachment	4	5.3 Flywheel	36	10.2.3 Adjustment	50
2.5 Special Accessories	5	5.4 Ground Wire/ Short Circuit Wire	37	10.3 Tank Vent	51
2.5.1 For User	5	5.5 Contact Spring	37	10.4 Pickup Body	51
2.5.2 For Service	5			10.5 Fuel Hoses	52
2.6 Tightening Torques	5			10.6 Tank Housing	53
3. Clutch, Chain Drive, Chain Brake and Chain Tensioner	7	6. Rewind Starter	38	11. Special Servicing Tools and Aids	56
3.1 Clutch Drum/ Chain Sprocket	7	6.1 General	38	11.1 Special Servicing Tools	56
3.2 Clutch	8	6.2 Rewind Spring	38	11.2 Servicing Aids	58
3.3 Chain Brake	9	6.2.1 Replacing	38		
3.3.1 Disassembly	9	6.2.2 Tensioning	39		
3.3.2 Assembly	10				
3.3.3 Checking Function	12	7. AV Handle System	40		
3.3.4 Brake Spring	13	8. Master Control/ Handle System	41		
3.3.5 Anchor Pin	13	8.1 Switch Shaft	41		
3.3.5 Hand Guard Pivot Pin	13	8.2 Throttle Trigger/ Interlock Lever	42		
3.4 Chain Tensioner	14				
4. Engine	15	9. Chain Lubrication	43		
4.1 Exhaust Muffler/ Spark Arresting Screen	15	9.1 Pickup Body/ Suction Hose	43		
4.2 Leakage Test	16	9.2 Valve	44		
4.2.1 Preparations	16	9.3 Spur Gear	44		
4.2.2 Pressure Test	17	9.4 Oil Pump	45		
4.2.3 Vacuum Test	18	9.4.1 Removing and Installing	45		
4.3 Oil Seals	19	9.4.2 Servicing	45		
4.4 Exposing the Cylinder	20				
4.5 Cylinder and Piston	20				
4.5.1 Removal	20				
4.5.2 Installation	21				
4.6 Piston Rings	24				
4.7 Crankcase	24				
4.7.1 Removing the Crankshaft	24				
4.7.2 Installing the Crankshaft	28				
4.8 Decompression Valve	32				

STIHL[®]

© 1996. Andreas Stihl. Waiblingen

1. INTRODUCTION

This service manual contains detailed descriptions of all the repair and servicing procedures specific to this series of chainsaws. There are separate handbooks for servicing procedures on standardized parts and assemblies that are installed in several STIHL power tool models. Reference is made to these handbooks in the appropriate chapters of this manual.

You should make use of the illustrated parts lists while carrying out repair work. They show the installed positions of the individual components and assemblies.

Always use the latest edition of the parts list to determine the part numbers of any replacement parts required. Microfilmed parts list are always more up to date than printed lists.

A fault on the machine may have several causes. Consult the troubleshooting charts for all assemblies in the "Standard Repairs, Troubleshooting" handbook.

Refer to the "Technical Information" bulletins for engineering changes which have been introduced since publication of this service manual. Technical information bulletins also supplement the parts list until a revised edition is issued.

The special servicing tools mentioned in the descriptions are listed in the last chapter of this manual. Use the part numbers to identify the tools in the "STIHL Special Tools" manual. The manual lists all special servicing tools currently available from STIHL.

Symbols are included in the text and pictures for greater clarity. The meanings are as follows:

In the descriptions:

- = Action to be taken as shown in the illustration (above the text)
- = Action to be taken that is not shown in the illustration (above the text)

In the illustrations:

- ➔ = Pointer
- ➔ = Direction of movement

Service manuals and all technical information bulletins describing engineering changes are intended exclusively for the use of STIHL servicing dealers. They must not be passed to third parties.

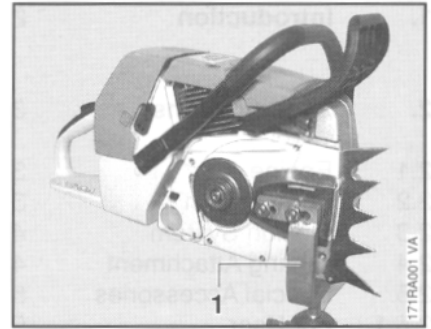

Servicing and repairs are made considerably easier if the powerhead is mounted to the assembly stand (1) 5910 890 3100.

This enables the powerhead to be swivelled to the best position for the ongoing repair and leaves both hands free.

Always use original STIHL replacement parts. They can be identified by the STIHL part number, the **STIHL** logo and the STIHL parts symbol . The symbol may appear alone on small parts.

2. SPECIFICATIONS

2.1 Engine

STIHL single cylinder two-stroke engine with special impregnated cylinder bore

Displacement:	121.6 cm ³ (7.42 cu.in)
Bore:	60 mm (2.35 in)
Stroke:	43 mm (1.69 in)
Engine power:	6.3 kW (8.6 bhp)
Max. torque:	8.0 Nm (5.9 lb.ft) at 6,000 rpm
Max. engine speed:	12,000 rpm
Main bearings:	Two deep-groove ball bearings
Big-end bearing:	Needle cage
Small-end bearing:	Needle cage
Piston pin diameter:	13 mm (0.51 in)
Connecting rod length:	75 mm (2.95 in)
Rewind starter:	ElastoStart
Pawls:	Two-pawl system
Reserve pull on rope rotor:	min. 2 turns
Starter rope:	4.5 mm (0.18 in) dia., 1000 mm (39.4 in) long
Clutch:	Centrifugal clutch without linings
Diameter:	87 mm (3.4 in)
Clutch engages at:	3.200 rpm
Crankcase leakage test at gauge pressure:	0.6 bar (8.7 psi)
under vacuum:	0.4 bar (5.8 psi)

2.2 Fuel System

Carburetor:	Diaphragm carburetor
Standard setting	
High speed screw H:	Open approx. 1 turn
Low speed screw L:	Open approx. 1 turn
Carburetor leakage test at gauge pressure:	0.8 bar (11.6 psi)
Function of tank vent at gauge pressure:	≤ 0.5 bar (7.25 psi)
under vacuum:	≤ 0.1 bar (1.45 psi)
Fuel tank capacity:	1.3 l (2.75 US pt)
Octane number:	min. 90 RON (US/CAN: pump octane min. 87 unleaded)
Fuel mixture:	Regular brand-name gasoline and two-stroke engine oil
Mix ratio:	50:1 with STIHL 50:1 two-stroke engine oil 25:1 with other brand-name two-stroke, air cooled engine oils
Air filter:	Standard filter (green) with wire mesh element for normal operating conditions and winter operation or HD filter (special accessory)

2.3. Ignition System	Type: Air gap: Ignition timing: Spark plug (suppressed): Electrode gap: Spark plug thread: Length of thread: Heat range:	Electronic magneto ignition (breakerless) with integral trigger unit 0.2 - 0.3 mm (0.008-0.012 in) 2.3 - 3.3 mm (0.091-0.130 in) B.T.D.C. at 8,000 rpm Bosch WSR 6F or NGK BPMR 7 A 0.5 mm (0.02 in) M14x1.25 9.5 mm (0.37 in) 200
2.4 Cutting Attachment	Guide bars Bar tail: Bar lengths: Oilomatic chain: Chain sprockets: Chain speed: Chain lubrication: Oil delivery rate: Oil tank capacity:	STIHL Rollomatic with nose sprocket STIHL Duromatic with Stellite-tipped nose. Both types with corrosion- resistant finish and induction hardened rails. 3002 Rollomatic: 53, 63, 75, 90 and 105 cm (21, 25, 30, 35 and 41 in) Duromatic: 53, 63, 75, 90, 105, 120 and 150 cm (21, 25, 30, 35, 47, 59 in) 10.26 mm (0.404") Rapid-Micro and Rapid-Super (standard equipment) 9.32 mm (3/8") Rapid-Micro and Rapid-Super as well as 12.7 mm (1/2") Rapid-Standard available as options 7-tooth 0.404" rim or spur sprocket (standard equipment) 8-tooth 3/8" rim and spur sprockets 23.9 m/s (78.4 ft/sec) at 8,500 rpm (with 7-tooth 0.404" sprocket) Fully automatic speed-controlled reciprocating oil pump, no oil feed at idle speed. Additional manual oil flow control (with E -matic mark) Adjustable 17 - 38 cm ³ /min (0.6 - 1.3 fl.oz/min) at 10,000 rpm 0.70 l (1.48 US pt)

2.5 Special Accessories

2.5.1	For User	STIHL repair kit 084/088	1124 900 5001
		HD air filter kit	0000 120 1650
		Intake air preheating kit	1124 007 1005
2.5.2	For Service	Carburetor parts kit	1124 007 1061
		Gasket kit 088	1124 007 1051

2.6 Tightening Torques

Plastoform screws are used for polymer components. These screws form a permanent thread when they are installed for the first time. They can be removed and installed as often as necessary without detrimentally affecting the strength of the screwed assembly, providing the specified tightening torque is observed. For this reason it is **essential to use a torque wrench**.

Fastener	Thread size	For component	Torque		Remarks
			Nm	lbf.ft	
Spline screw	IS-B3.9x13	Cover plate/sprocket cover	1.5	1.1	
Spline screw	IS-B3.9x19	Tank housing/handle molding	1.0	0.75	
Spline screw	IS-B3.9x19	Switch shaft pivot/tank housing	1.0	0.75	
Spline screw	IS-M4x8	Cover plate/chain tensioner	3.0	2.2	
Spline screw	IS-M4x8	Inner side plate/crankcase	3.0	2.2	
Spline screw	IS-M4x12	Segment/fan housing	2.5	1.8	
Spline screw	IS-M4x12	Oil pump/crankcase front, bottom, rear	3.5	2.6	
Spline screw	IS-M4x12	Chain brake cover/crankcase	3.0	2.2	
Spline screw	IS-M4x12	Oil pump/crankcase front top	3.5	2.6	1)
Spline screw	IS-M4x12	Brake band/crankcase	3.0	2.2	2)
Spline screw	IS-M4x12	Oil pump cover/crankcase	3.0	2.2	
Spline screw	IS-M4x12	Exhaust cover/muffler	4.0	3.0	
Spline screw	IS-M4x12	Spur gear cover/crankcase	3.0	2.2	
Collar nut	M5	Shroud/cylinder	7.0	5.2	
Collar nut	M5	Tank housing/carburetor/flange	5.0	3.7	
Spline screw	IS-M5x12	Top left annular buffer plate/ crankcase	9.0	6.6	2)
Spline screw	IS-M5x16	Support/muffler	10.0	7.5	
Spline screw	IS-M5x20	Shroud/crankcase	7.0	5.2	

Fastener	Thread size	For component	Torque		Remarks
			Nm	lbf.ft	
Spline screw	IS-M5x20	Fan housing/crankcase	7.0	5.2	
Screw assembly	IS-M5x35	Hand guard/fan housing/ crankcase	7.0	5.2	2)
Spline screw	IS-M5x25	Ignition module/crankcase	9.0	6.6	2)
Spline screw	IS-M5x25	Crankcase	11.5	8.5	
Nut	M6	Spiked bumper/chain sprocket cover	7.5	5.5	
Spline screw	IS-M6x18	Spiked bumper/crankcase, bottom	7.5	5.5	2)
Spline screw	IS-M6x18	Spiked bumper/crankcase, top	7.5	5.5	
Spline screw	IS-M5x16	Support/crankcase	10.0	7.5	
Spline screw	IS-M6x40	Annular buffer, top left/tank housing	7.0	5.2	2)
Spline screw	IS-M6x30	Cylinder/crankcase	15.0	3.7	
Nut	M10x1	Flywheel/crankshaft	45.0	33.0	
	M10x1	Decompression valve	14.0	10.3	
	M 10x27	Bar mounting stud	30.0	22.0	2)
	M14x1	Clutch carrier/crankshaft	80.0	59.0	
	M 14x1.25	Spark plug	25.0	18.5	
Plastoform screw	IS-P6x19	Annular buffer, bottom/tank housing	5.5	4.0	
Plastoform screw	IS-P6x21.5	Front handle, bottom/tank housing	8.0	5.9	3)
Plastoform screw	IS-P6x32.5 1.8	Front handle, right, stiffener/ tank housing	8.0	5.9	3)
Nut	M5	Chain catcher/spiked bumper	6.0	4.4	4)

Use the following procedure when refitting a Plastoform screw in an existing thread:

- Place the screw in the hole and rotate it counterclockwise until it drops down slightly.
- Tighten the screw clockwise to the specified torque.

This procedure ensures that the screw engages properly in the existing thread and does not form a new thread and weaken the joint.

- 1) Sealant (Hylomar)
- 2) Screw secured with Loctite 242
- 3) Screw secured with Loctite 648
- 4) R version only

Note: Use hot air blower (hair dryer) to release screws secured with adhesive.

Take special care with polymer components.

Power screwdriver speed for use in polymer:

Plastoform screws max. 600 rpm,

DG screws max. 500 rpm.

3. CLUTCH, CHAIN DRIVE, CHAIN BRAKE AND CHAIN TENSIONER
3.1 Clutch Drum/Chain Sprocket

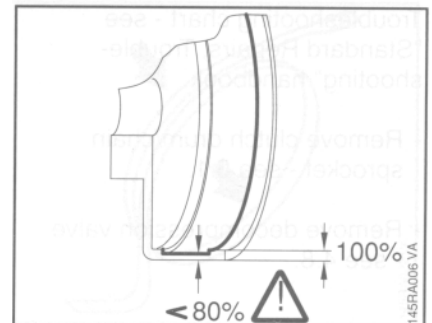
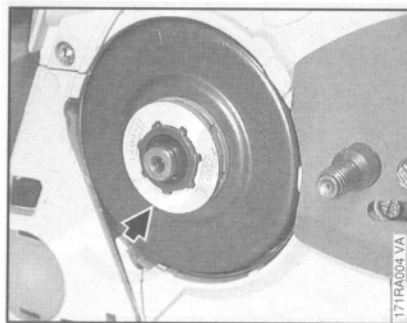
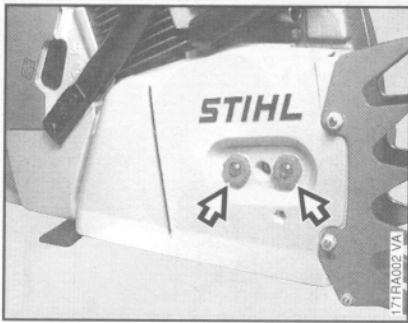

- Unscrew nuts.
- Remove the chain sprocket cover.

- If a rim sprocket is fitted, pull it off.

Important: If there are noticeable wear marks on the inside diameter of the clutch drum, check its wall thickness. If it is less than 80% of the original wall thickness, fit a new clutch drum.

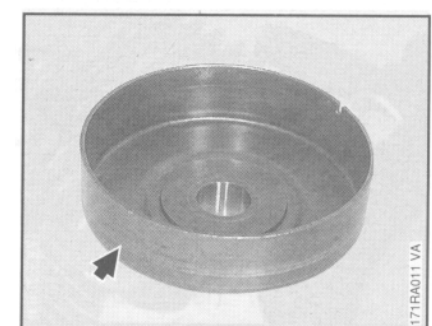
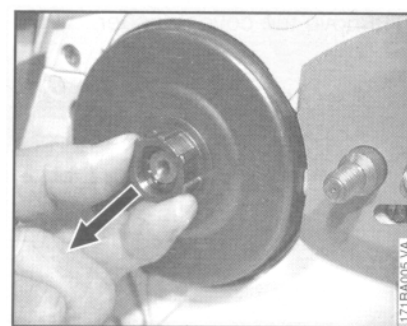
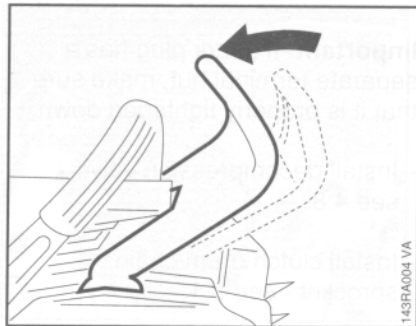

- Disengage the chain brake by pulling the hand guard toward the front handle.

- Pull off the clutch drum/chain sprocket.

Note: If the clutch drum has to be replaced, also check the brake band - see 3.3.

- If the clutch drum is still serviceable, use No. 120 emery paper or emery cloth (grain size approx. 120µm) to clean and roughen its friction surface.

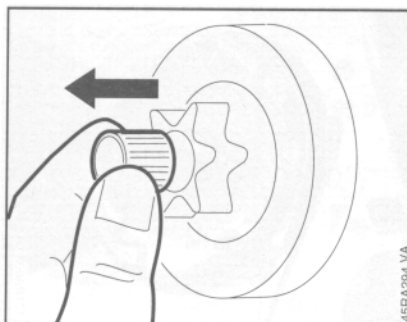
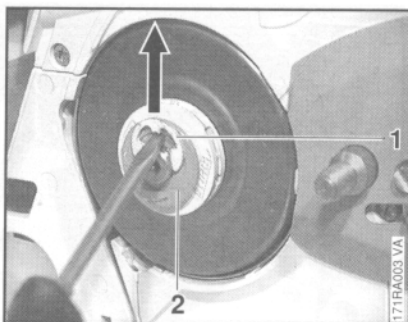

Reassemble in the reverse sequence.

- Remove the E-clip (1).
- Remove the washer (2).

- Take the needle cage out of the sprocket.
- Clean and inspect the clutch drum/chain sprocket.

- Clean stub of crankshaft. Wash needle cage in clean white spirit and lubricate with grease - see 11.2.
- Replace damaged needle cage.
- Rotate clutch drum/chain sprocket and apply slight pressure at the same same until oil pump drive spring engages properly.

3.2 Clutch

Troubleshooting chart - see "Standard Repairs, Troubleshooting" handbook.

- Remove clutch drum/chain sprocket - see 3.1.
- Remove decompression valve - see 4.8.

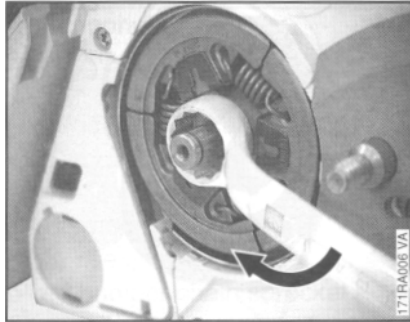

- Unscrew the clutch from the crankshaft in the direction of the arrow (left-hand thread).
- Disassemble and reassemble the clutch - see "Standard Repairs, Troubleshooting" handbook.
- Remove the cover washer.

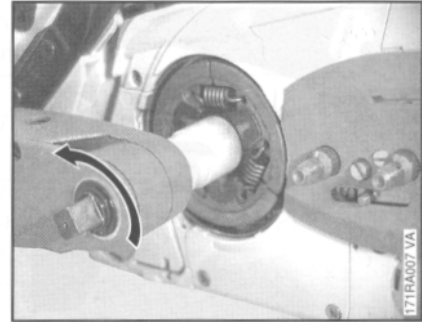

- Screw clutch onto crankshaft and torque down to 80 Nm (59 lbf.ft).
- Remove locking strip from cylinder.
- Install spark plug and torque down to 25 Nm (18.5 lbf.ft).

Important: If spark plug has a separate terminal nut, make sure that it is properly tightened down.

- Install decompression valve - see 4.8.
- Install clutch drum/chain sprocket - see 3.1.

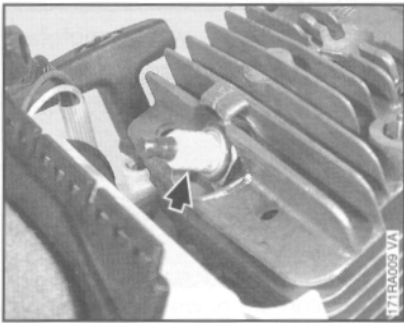

- Unscrew the spark plug.

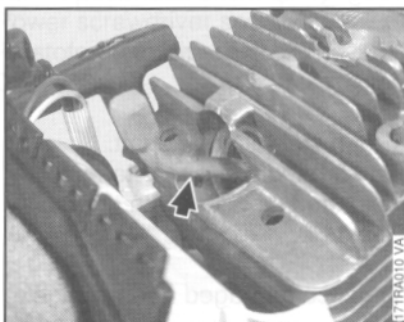

- Push the locking strip 0000 893 5903 into the cylinder.

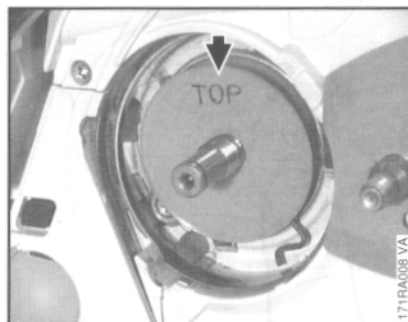

- Fit cover washer so that "TOP" faces outward.

3.3 Chain Brake
3.3.1 Disassembly

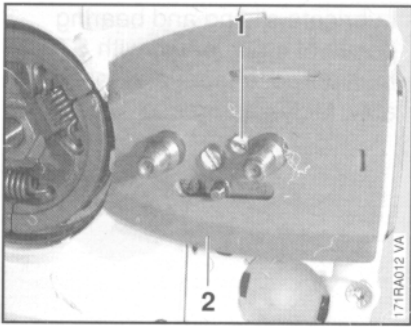

- Remove clutch drum/chain sprocket - see 3.1.
- Take out the screw (1).
- Remove the side plate (2).

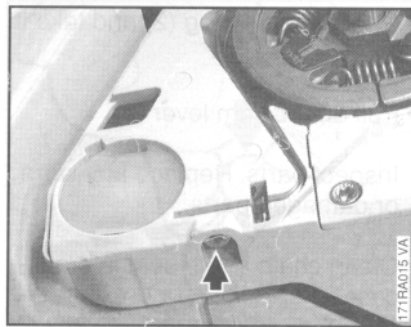

- Take out the brake band fastening screw.

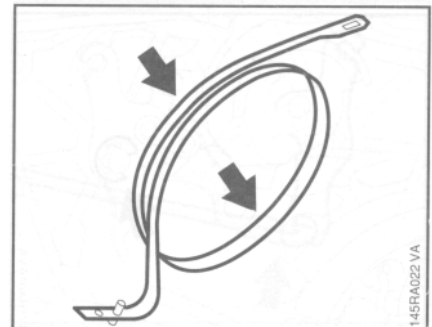

Replace the brake band if:

- there are noticeable signs of wear (large areas on inside diameter and/or parts of outside diameter) and
- its remaining thickness is $< 0.6 \text{ mm}$ (0.024").

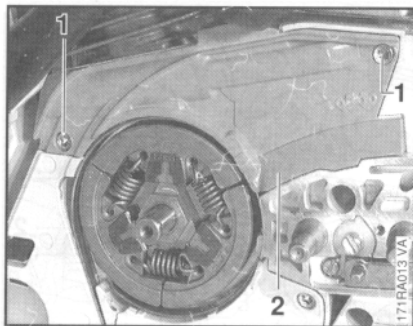

- Relieve tension of brake spring by pushing the hand guard forward.
- Take out the screws (1).
- Lift away the cover (2).

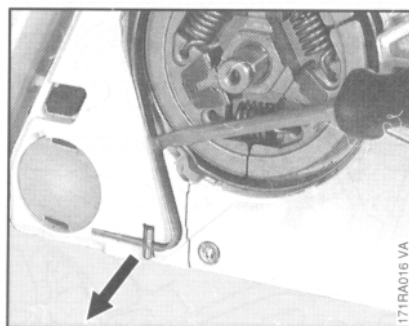

- Lever the brake band out of the crankcase.

Important! Thickness of brake band must not be less at any point.

- If the brake band is still serviceable, use No. 120 emery paper or emery cloth (grain size approx. $120\mu\text{m}$) to clean and roughen its entire friction surface (inside diameter).

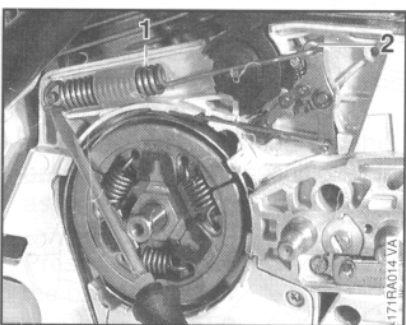

- Carefully pry the brake spring (1) off the anchor pin and unhook it from the bell crank (2).

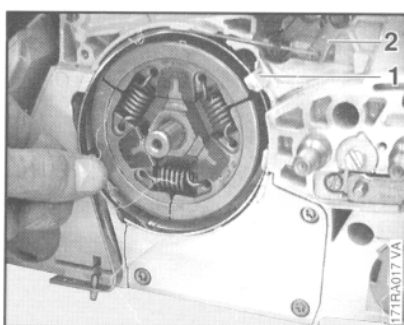

- Remove the brake band from the lugs (1) on the crankcase.
- Unhook the brake band from the bell crank (2).

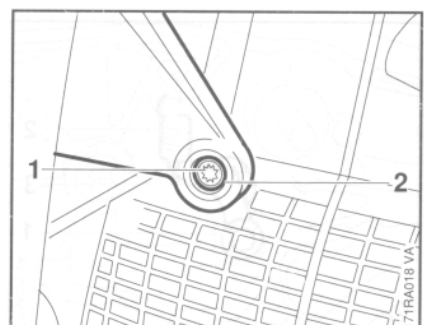

- Take out the screw (1).
- Remove the rubber bushing (2).
- Inspect parts and replace if damaged.

3.3.2 Assembly

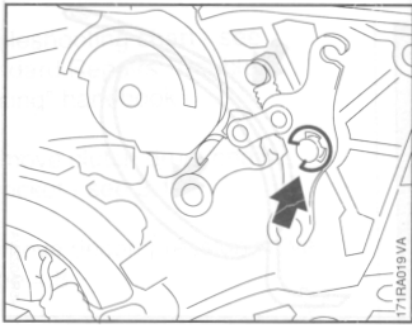

- Ease the E-clip off the bell crank pivot pin.

- Unhook the spring (2) and take it away.
- Pull off the cam lever (3).
- Inspect parts. Replace any worn or damaged parts.
- Clean chain brake seat in crankcase.
- If the groove of the brake spring anchor pin is worn, the anchor pin must be replaced - see 3.3.4.

- Lubricate sliding and bearing points of chain brake with STIHL multipurpose grease or, preferably, Molykote grease - see 11.2.

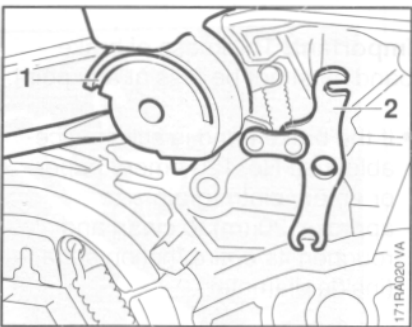

- Carefully ease the hand guard (1) and bell crank (2) off the pivot pins and lift them away together.
- Pull the bell crank out of the hand guard.

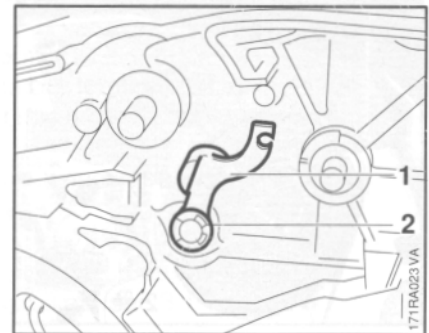

- Push the cam lever (1) onto the pivot pin.
- Fit the E-clip (2).

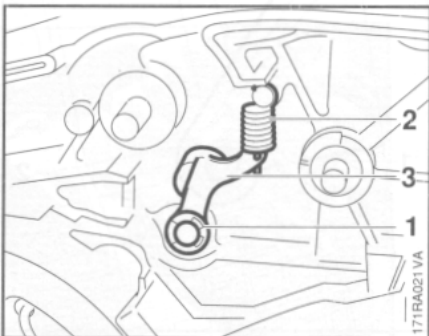

- Remove the E-clip (1).

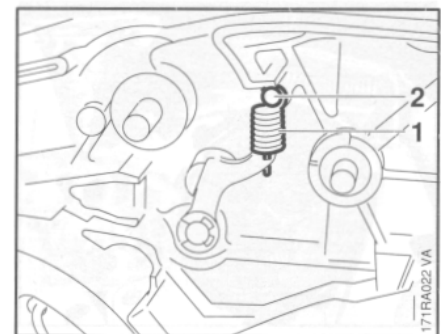

- Attach the spring (1) to the pivot pin (2) and cam lever.

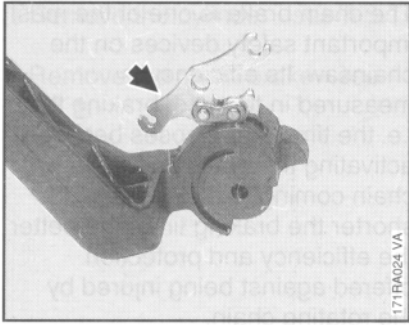

- Insert the bell crank in the side of the hand guard so that the short arm of the bell crank points up.

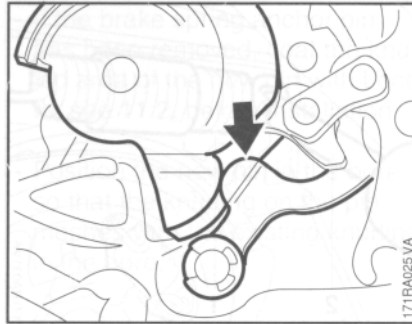

- Check that cam lever is properly located on face of hand guard bearing boss.

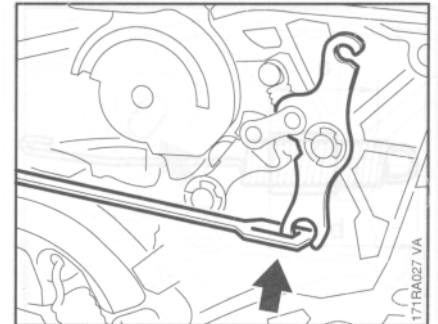

- Hook the brake spring onto the bell crank.
- Position the brake band behind the lugs on the crankcase.

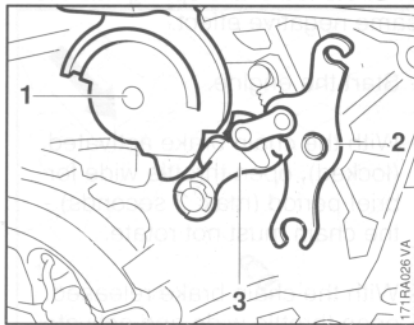

- Position the hand guard (1) against the pivot pin and fit the other side of the hand guard over, the housing.
- Position the bell crank (2) against the pivot pin.
- Press the cam lever (3) slightly downward and push the hand guard and bell crank onto their pivot pins.
- Push the metal bushing into the back of the rubber bushing as far as shoulder.
- Press the rubber bushing into the hand guard.
- Fit hand guard mounting screw and tighten to 7.0 Nm (5.2 lbf.ft).

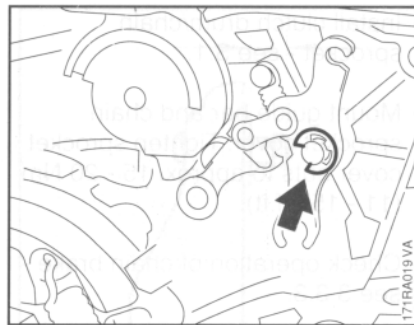

- Secure bell crank with E-clip.
- Coat brake band with chain oil (STIHL Bioplus), see 11.2, to protect it from corrosion and cushion "snatching" during the first few brake applications.

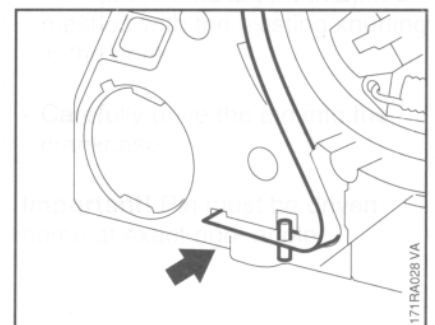

- Press brake band into slot.
- Coat the mounting screw with Loctite, see 11.2. and torque down to 3.0 Nm (2.2 lbf.ft).

3.3.3 Checking Function

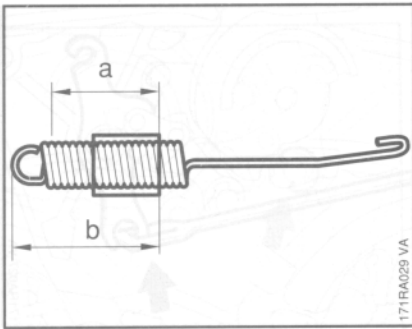

- Coils of brake spring must locate tight against one another in relaxed condition. Install a new brake spring if necessary.
- Check that protective tube is correctly positioned:
a = 20 mm (3/4")
b = 42 mm (1 5/8")

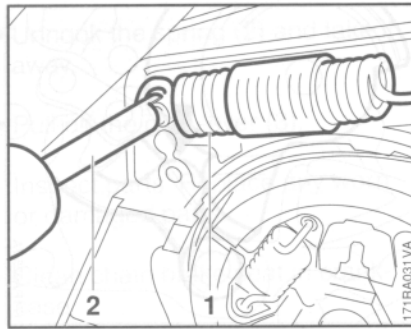

- Use the assembly tool (2) 1117 890 0900 to attach the brake spring (1) to the anchor pin.
- Fit cover over the chain brake.
- Fit the side plate.
- Install clutch drum/chain sprocket - see 3.1.
- Mount guide bar and chain sprocket cover. Tighten sprocket cover nuts to approx. 15 - 20 Nm (11 - 15 lbf.ft).
- Check operation of chain brake - see 3.3.3.

The chain brake is one of the most important safety devices on the chainsaw. Its efficiency is measured in terms of braking time, i.e. the time that elapses between activating the brake and the saw chain coming to a standstill. The shorter the braking time, the better the efficiency and protection offered against being injured by the rotating chain.

Contamination (with chain oil, chips, fine particles of abrasion, etc.) and smoothing of the friction surfaces of the brake band and clutch drum impair the coefficient of friction. This, in turn, reduces the frictional forces and thus prolongs the braking time. A fatigued or stretched brake spring has the same negative effect.

- Start the engine.
- With the chain brake activated (locked), open throttle wide for brief period (max. 3 seconds) the chain must not rotate.
- With the chain brake released,
 - open throttle wide and activate the brake manually - the chain must come to an abrupt stop.

Note: The braking time is in order if deceleration of the saw chain is imperceptible to the eye.

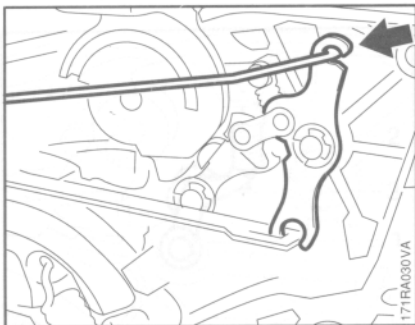

- Attach the brake spring to the bell crank.

3.3.4 Brake Spring Anchor Pin

- Remove the cylinder - see 4.5.1.
- Remove the chain brake – see 3.3.1.
- If the brake spring anchor pin has been removed, coat the knurled area of the new pin with Loctite, see 11.2, before installation.
- Position the new pin in the bore so that the knurling on the pin meshes with the existing knurling in the bore.

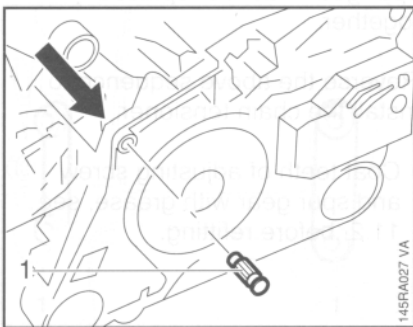

- Use a suitable punch to drive the anchor pin out of the crankcase in the direction of the arrow.

Important! Do not drive out the pin in the other direction as this would damage the annular bead which was formed in the crankcase bore when the pin was originally installed. In such a case neither the new anchor pin nor the brake spring would locate properly. Furthermore, the crankcase could be damaged in this way and possibly impair correct operation of the chain brake.

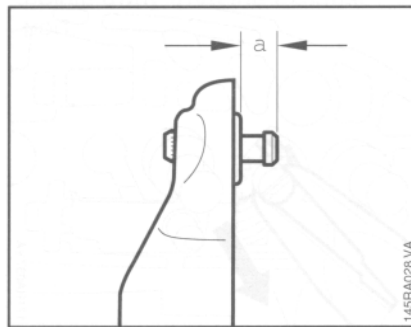

- Carefully tap home the pin squarely to obtain dimension "a" = 4.3 - 4.7 mm (11/64").

Important! Pin must be driven home at exact right angle.

- Install the cylinder - see 4.5.2.
- Install the chain brake - see 3.3.2.

3.3.5 Hand Guard Pivot

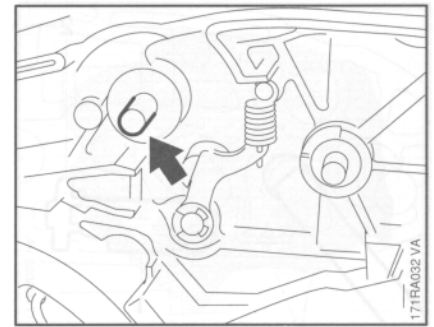

- Use pliers to grip the pivot pin and pull it out of the crankcase.
- Coat the knurled area of the new pin with Loctite, see 11.2, before installation.
- Position the new pin in the bore so that the knurling on the pin meshes with the existing knurling in the bore.
- Carefully drive the pin into the crankcase.

Important! Pin must be driven home at exact right angle.

3.4 Chain Tensioner

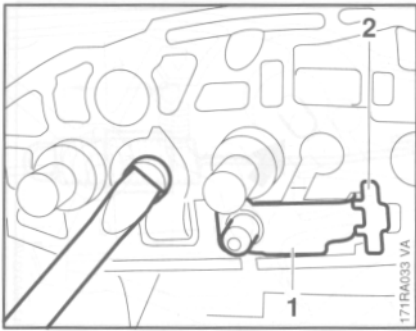

- Remove inner side plate - see 3.3.1.
- Rotate the spur gear clockwise until the tensioner slide (1) butts against the thrust pad (2).

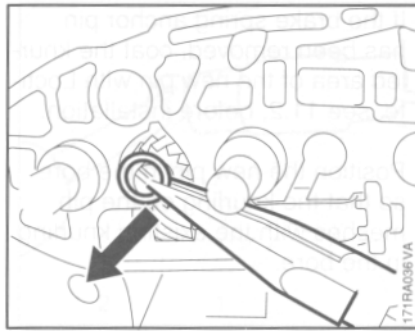

- Take out the brake washer.

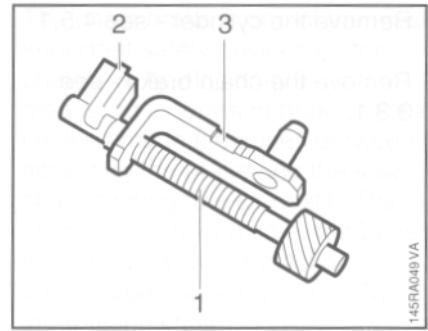

- Inspect the teeth on the spur gear and adjusting screw (1). If the teeth are damaged, pull off the thrust pad (2), take the adjusting screw out of the tensioner slide (3) and replace both parts.

Note: The adjusting screw and spur gear must be replaced together.

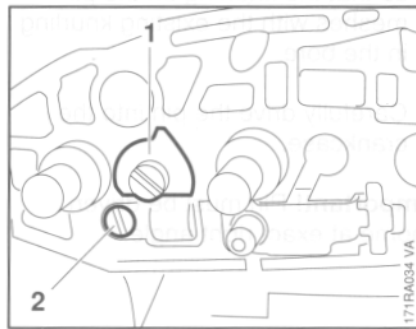

- Take out the retainer (1).
- Take out the screw (2).

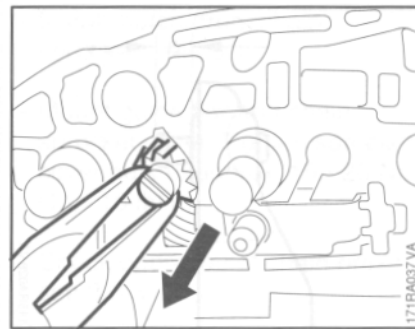

- Pull out the spur gear.

Reverse the above sequence to install the chain tensioner.

- Coat teeth of adjusting screw and spur gear with grease, see 11.2, before refitting.

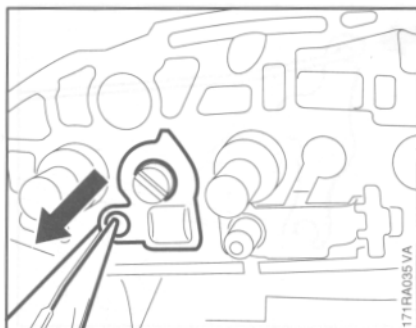

- Remove the cover plate.

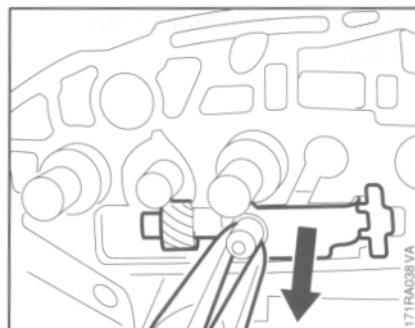

- Take out the tensioner slide with adjusting screw and thrust pad.

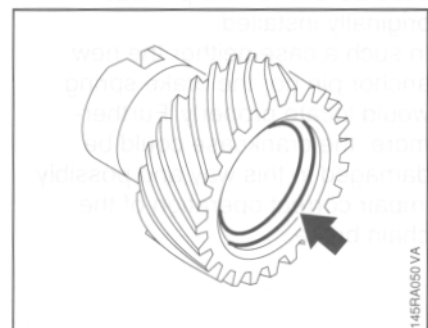

- Check that O-ring is fitted in spur gear and lubricate it with a little oil before installing.

4. ENGINE
4.1 Exhaust Muffler/Spark Arresting Screen

Troubleshooting chart - see "Standard Repairs, Troubleshooting" handbook.

- Remove the shroud - see 4.8.

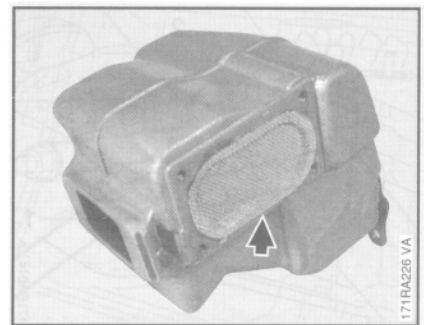
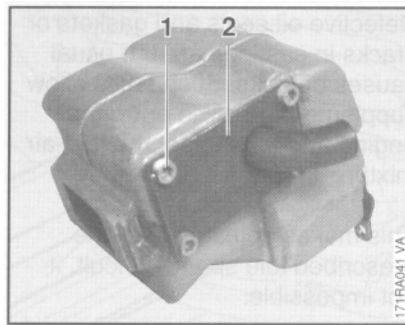

Muffler without spark arresting screen

- Take out the screws (1).
- Remove the cover (2).
- Fit the cover so that the stub points away from the exhaust port.

- Remove the spark arresting screen.
- Clean the spark arresting screen or fit a new one.

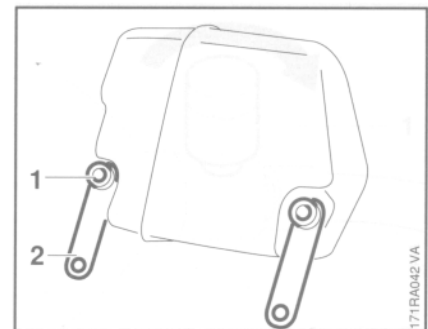
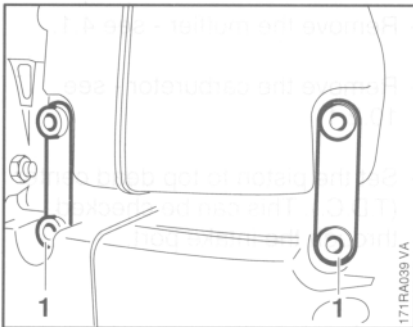

- Take out the screws.

- Take out the screws (1)
- Remove the strap (2)

Muffler with spark arresting screen

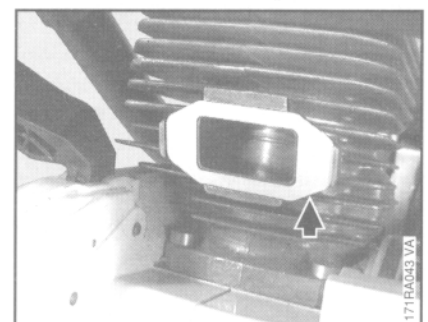
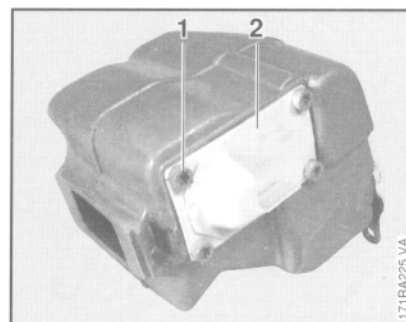
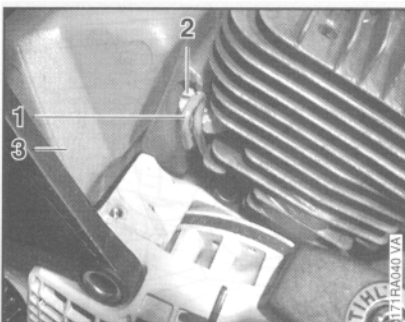

- Ease away the clips (1).
- Remove the retainers (2).
- Remove the muffler (3).

- Take out the screws (1).
- Remove the cover (2).

- Remove the exhaust gasket.

Reassemble in the reverse sequence.

4.2 Leakage Test

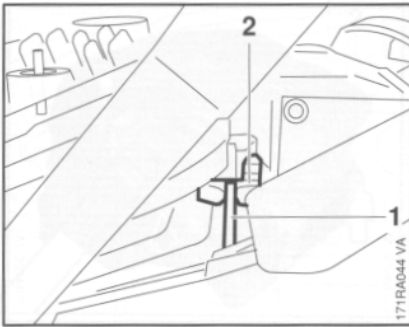

- Install a new exhaust gasket.
- Attach clip (1) to retainer (2).
- Tightening torques - see 2.6.

Defective oil seals and gaskets or cracks in castings are the usual causes of leaks. Such faults allow supplementary air to enter the engine and thus upset the fuel-air mixture.

This makes adjustment of the prescribed idle speed difficult, if not impossible.

Moreover, the transition from idle speed to part or full throttle is not smooth.

The crankcase can be checked thoroughly for leaks with the carburetor and crankcase tester and the vacuum pump.

4.2.1 Preparations

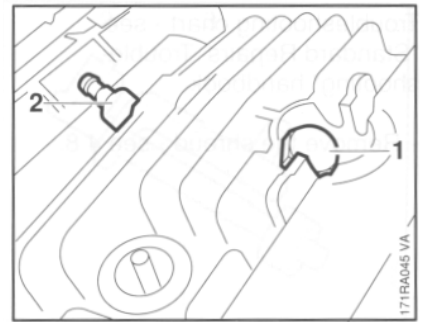

- Remove decompression valve - see 4.8.
- Install plug (1) 1122 025 2200 and tighten to 14 Nm (10.3 lbf.ft).
- Check that spark plug (2) is properly tightened down.
- Remove the muffler - see 4.1.
- Remove the carburetor - see 10.2.1.
- Set the piston to top dead center (T.D.C.). This can be checked through the intake port.

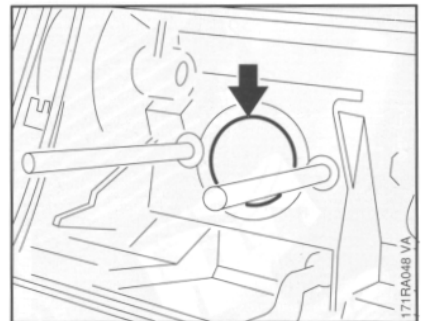

- Check that sleeve is in position.

4.2.2 Pressure Test

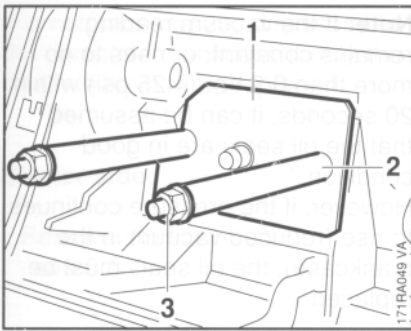

- Push the test flange (1) 1106 850 4201 into position.
- Fit sleeves (2) 1127 851 8300.
- Fit nuts (3) and tighten down firmly.

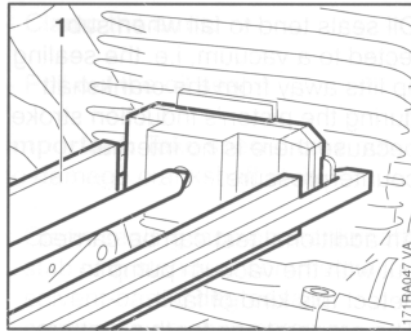

- Mount the clamp (1) 0000 890 4400.

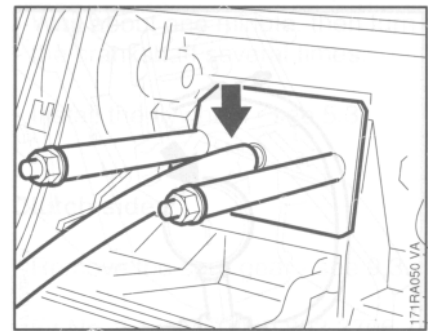

- Connect pressure hose of tester 1106 850 2905 to nipple on test flange.

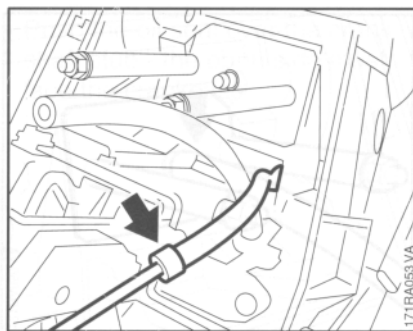

- Seal the end of the impulse hose with a pointed piece of round stock (3 mm dia.) or a scriber.

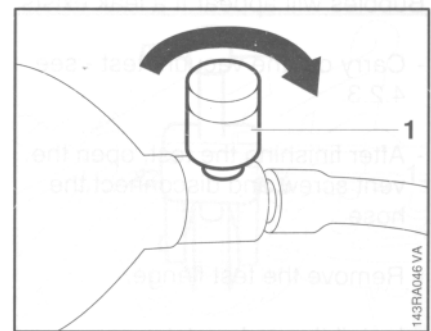

- Close the vent screw (1) on the rubber bulb.
- Pump air into the crankcase with rubber bulb until the gauge indicates a pressure of 0.6 bar (8.7 psi). If this pressure remains constant for at least 20 seconds, the crankcase is airtight.

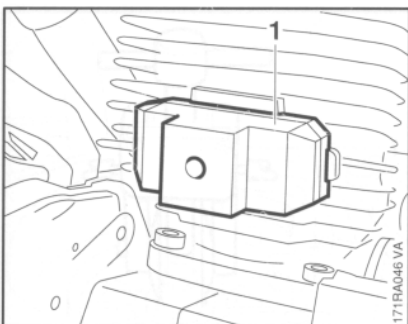

- Fit the flange (1) 1124 850 4205 in position.

4.2.3 Vacuum Test

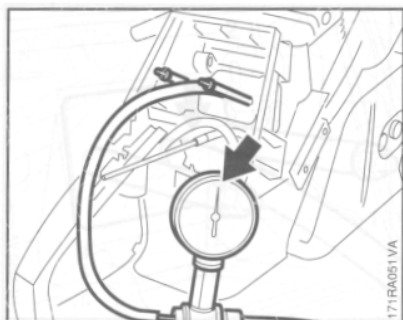

Oil seals tend to fail when subjected to a vacuum, i.e. the sealing lip lifts away from the crankshaft during the piston's induction stroke because there is no internal counterpressure.

An additional test can be carried out with the vacuum pump to detect this kind of fault. The preparations for this test are the same as for the pressure test see 4.2.2.

- However, if the indicated pressure drops, the leak must be located and the faulty part replaced.

Note: To find the leak, coat the suspect area with oil and pressurize the crankcase again. Bubbles will appear if a leak exists.

- Carry out the vacuum test - see 4.2.3.
- After finishing the test, open the vent screw and disconnect the hose.
- Remove the test flange.
- Install the carburetor - see 10.2.1.
- Remove the test flange with clamp.
- Install the muffler - see 4.1.
- Unscrew the plug from the cylinder.
- Install decompression valve see 4.8.

Note: If the vacuum reading remains constant, or rises to no more than 0.3 bar (4.25 psi) within 20 seconds, it can be assumed that the oil seals are in good condition.

However, if the pressure continues to rise (reduced vacuum in the crankcase), the oil seals must be replaced.

- After finishing the test, open the vent screw and disconnect the hose.
- Remove the test flange.
- Install the carburetor
 - see 10.2.1.
- Remove the test flange with clamp.
- Install the muffler - see 4.1.
- Unscrew the plug from the cylinder.
- Install decompression valve
 - see 4.8.

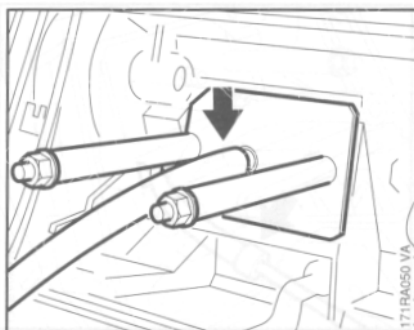

- Connect suction hose of vacuum pump 0000 850 3501 to test flange nipple.

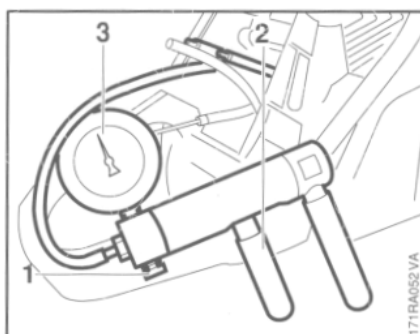

- Close the vent screw (1) on the pump.
- Operate lever (2) until pressure gauge (3) indicates a vacuum of 0.4 bar (5.8 psi).

4.3 Oil Seals

It is not necessary to disassemble the complete crankcase if only the oil seals have to be replaced.

Starter side:

- Remove the flywheel - see 5.3.

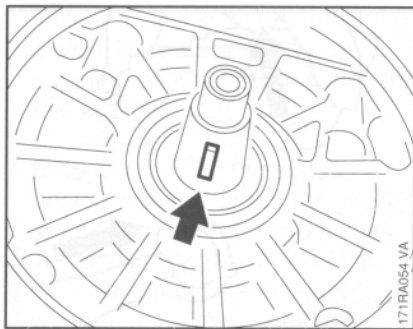

- Remove key from crankshaft.
- Use a suitable pipe or punch to carefully tap the oil seal and free it off.

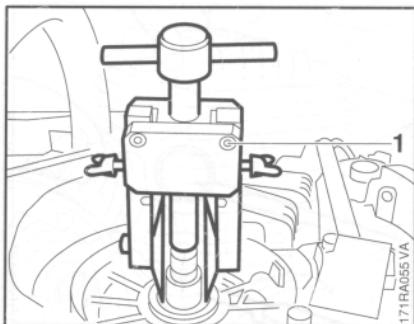

- Apply puller (1) 5910 890 4400 (with No. 3.1 jaws 0000 893 3706).

- Clamp the arms.
- Pull out the oil seal.

Important: Take special care not to damage crankshaft stub.

- Clean sealing face on crankshaft stub with standard commercial solvent-based degreasant containing no chlorinated or halogenated hydrocarbons – see 11.2.
- Lubricate sealing lips of oil seal with grease - see 11.2.
- Thinly coat the outside diameter of the oil seal with sealant - see 11.2.
- Push the oil seal over the crankshaft stub - the open side must face the crankcase.

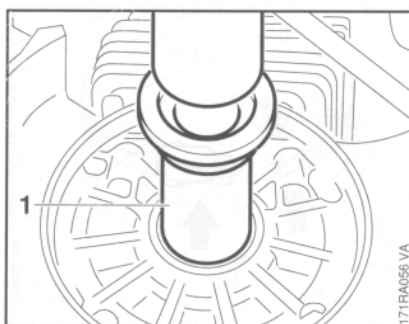

- Use the press sleeve (1) 1127 893 2400 to install the oil seal.

- Wait about one minute, then turn the crankshaft several times.
- Install the flywheel - see 5.3.

Clutch side:

- Remove the spur gear - see 9.3.
- Fit No. 3.1 jaws 0000 893 3706 to the puller.

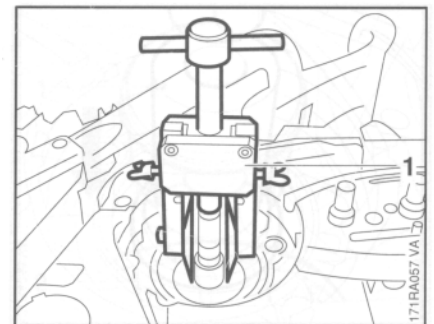

- Apply puller (1) 5910 890 4400.
- Clamp the arms.
- Pull out the oil seal.

Important: Take special care not to damage crankshaft stub.

- Clean sealing face on crankshaft stub with standard commercial solvent-based degreasant containing no chlorinated or halogenated hydrocarbons - see 11.2.
- Lubricate sealing lips of oil seal with grease - see 11.2.
- Apply thin coat of sealant (see 11.2) to outside diameter of oil seal.

4.4 Exposing the Cylinder

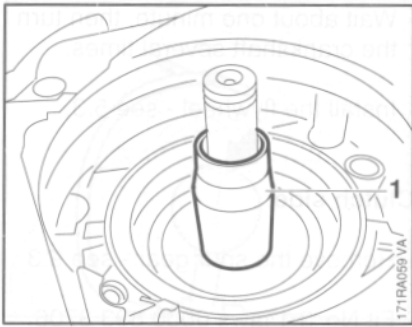

- Slip assembly sleeve (1) 1124 893 4600 over the crankshaft stub.

Always check and, if necessary, repair the fuel system, carburetor, air filter and ignition system before looking for faults on the engine.

Troubleshooting chart - see "Standard Repairs, Troubleshooting" handbook.

- Remove the muffler - see 4.1
- Remove the carburetor - see 10.2.1.
- Remove decompression valve - see 4.8.

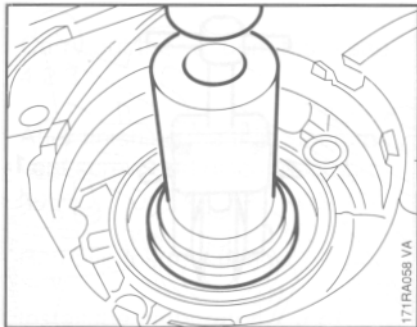

- Push the oil seal, open side facing the crankcase, over the assembly sleeve.
- Press oil seal home with press sleeve (1) 1127 893 2400.
- Remove the assembly sleeve.
- Wait about one minute, then turn the crankshaft several times.
- Install the spur gear - see 9.3.

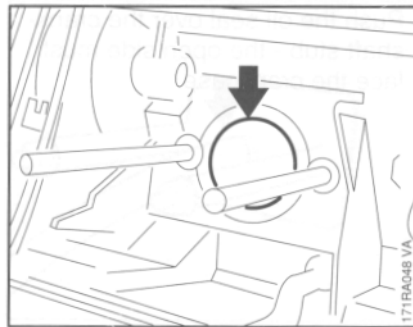

- Take the sleeve out of the manifold.

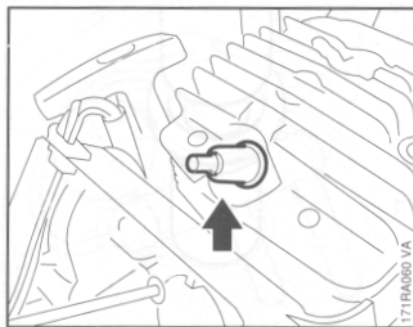

- Unscrew the spark plug.

Reassemble in the reverse sequence.

4.5 Cylinder and Piston Removal

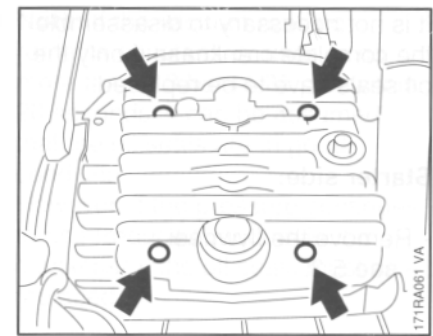

Preparations - see 4.4.

- Unscrew the four cylinder base screws through the holes in the cylinder.

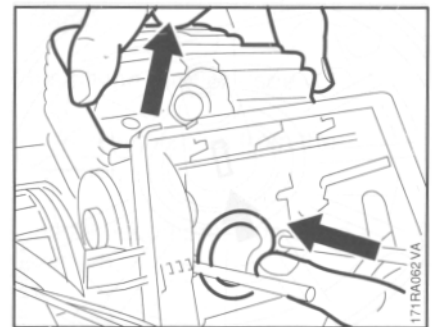

- Carefully lift the cylinder up and, at the same time, push the manifold through the tank housing opening.

Caution: Do not use pointed or sharp-edged tools.

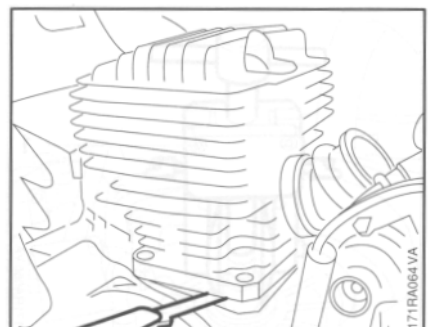

- Carefully separate the cylinder gasket from the cylinder base.
- Pull the cylinder off the piston.

4.5.2 Installation

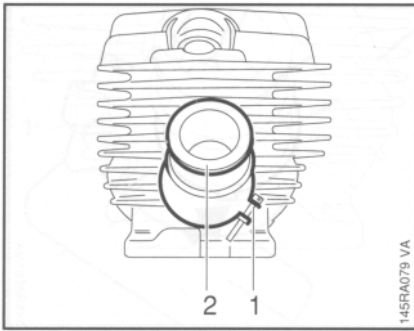

- Release the hose clamp (1).
- Pull the manifold (2) off the intake port.
- Inspect the cylinder and replace it if necessary.
- If a new cylinder has to be installed, always fit the matching piston. New cylinders are only supplied complete with piston for this reason.
- Before removing the piston, decide whether or not the crankshaft has to be removed as well. To remove the flywheel, block the crankshaft by sliding the wooden assembly block between the piston and crankcase.
- Remove the cylinder gasket.

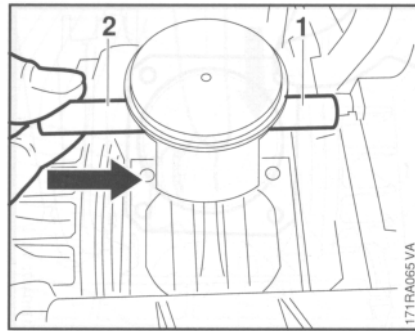

- Use the assembly drift (2) 1111 893 4700 to push the piston pin (1) out of the piston.

Note: If the piston pin is stuck, tap the end of the drift **lightly** with a hammer if necessary.

Important: Hold the piston steady during this process to ensure that no jolts are transmitted to the connecting rod.

- Remove piston and take the needle cage out of the connecting rod.

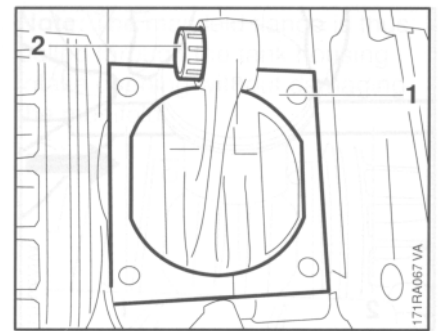

- Thoroughly clean the gasket seating surface (1).
- Lubricate the needle cage (2) with oil and fit it in the small end.

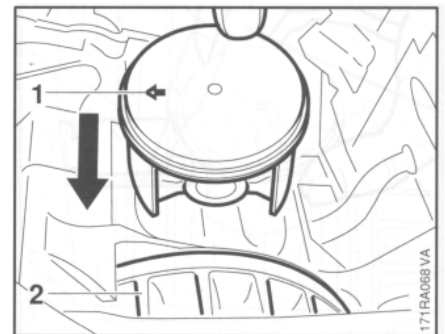

- To ease assembly, heat the piston slightly and slip it over the connecting rod.
- Check installed position of piston:
 - 1 = Mark
 - 2 = Flywheel

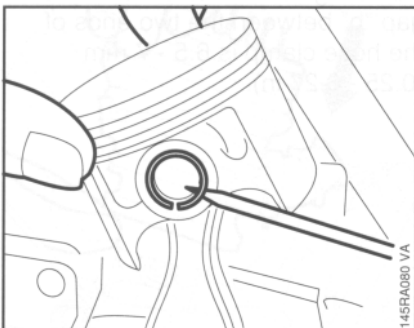

- Ease the hookless snap rings out of the grooves in the pistons.

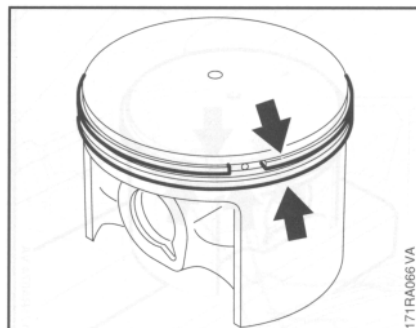

- Inspect piston rings and replace if necessary - see 4.6.

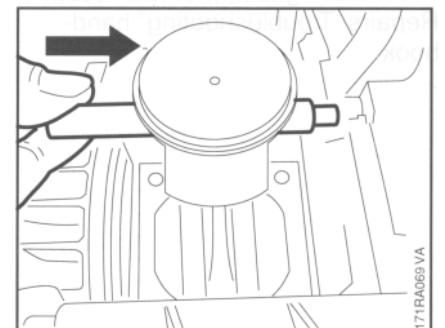

- Push the assembly drift, small diameter first, through the piston and small end (needle cage) and line up the piston.

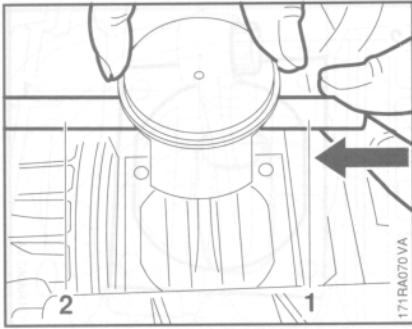

- Fit the piston pin (1) on the assembly drift (2) and slide it into the piston (the pin slides home easily if the piston is heated).

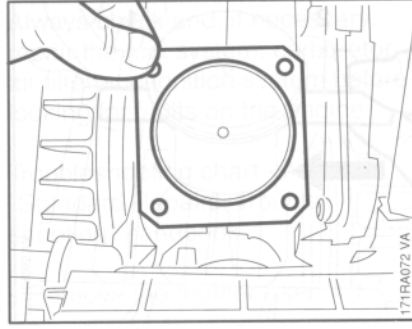

- Place new cylinder gasket in position.

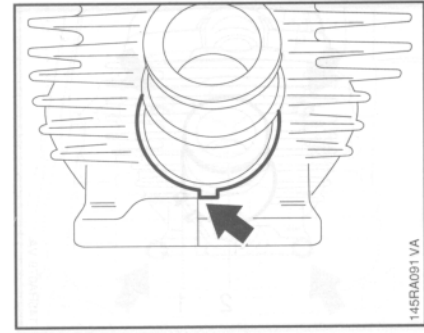

- Push the manifold onto the intake port.
- Note installed position of manifold.

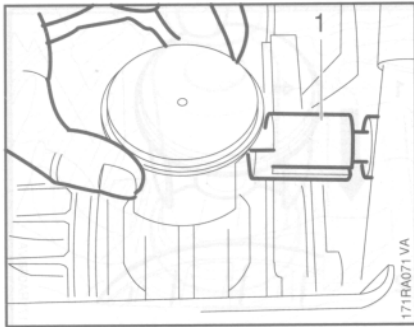

- Apply the installing tool (1) 5910 890 2212 to the piston boss, hold the piston steady, center the tool shank exactly and press home until the snap ring slips into the groove.

Note: For instructions on how to use installing tool, see "Standard Repairs, Troubleshooting" handbook.

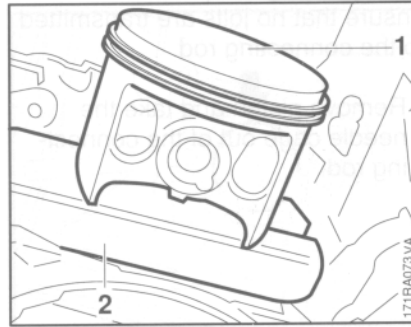

- Lubricate the piston and piston rings with oil and place the piston (1) on the wooden assembly block (2) 1108 893 4800.

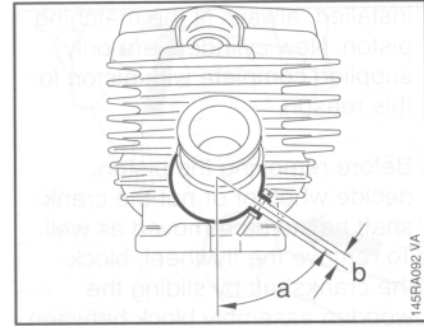

- Push the hose clamp over the manifold. The screw head must point to the right.
- Tighten the hose clamp. Ends of clamp must point down to the right at angle "a" of 45 degrees.

Note: Tighten the screw until the gap "b" between the two ends of the hose clamp is 6.5 - 7 mm (0.25 - 0.27 in).

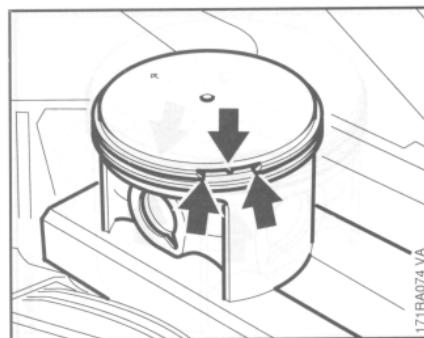

- Install the new piston rings in the grooves so that the radii at the ring gap face upward and meet at the fixing pin.

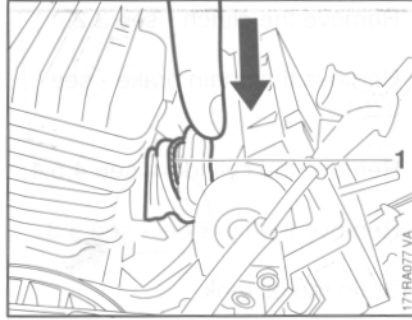
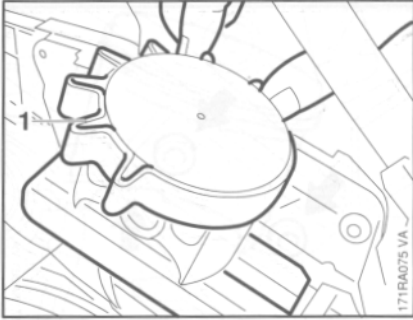

Note: The manifold flange is thus pulled through the tank housing intake opening without damaging the manifold.

- Use the clamping strap (1) 0000 893 2600 to compress the piston rings around the piston.
- Check that the piston rings are correctly positioned.
- Lubricate the inside of the cylinder with oil and line it up so that it is positioned as it will be in the installed condition. It is important to observe this point as the piston rings might otherwise break.
- Remove the clamping strap and wooden assembly block.
- To fit the manifold in the tank housing intake opening, wind a piece of string (1) (about 15 cm / 6" long) around the back of the manifold flange and pass the ends of the string through the intake opening.
- Push the manifold down.

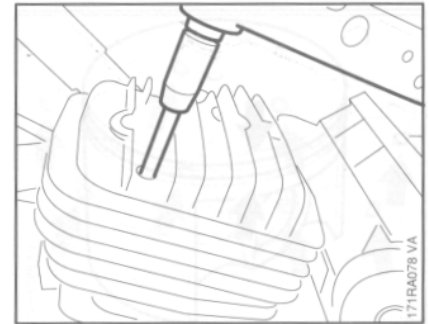

- Carefully line up the cylinder and gasket.
- Fit cylinder base screws and torque down to 15.0 Nm (11.0 lbf.ft) in diagonal pattern.

Assembly is now a reversal of the disassembly sequence

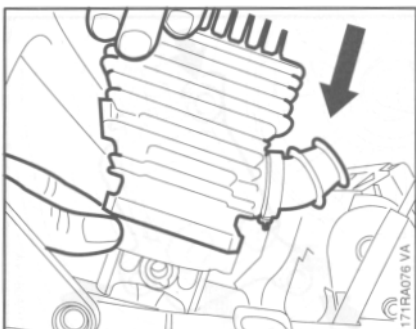

- Slide the cylinder over the piston - the clamping strap is pushed downward as the piston rings slip into the cylinder.
- Pull the ends of the string outward.

4.6 Piston Rings

- Remove the piston - see 4.5.1.
- Remove rings from piston.

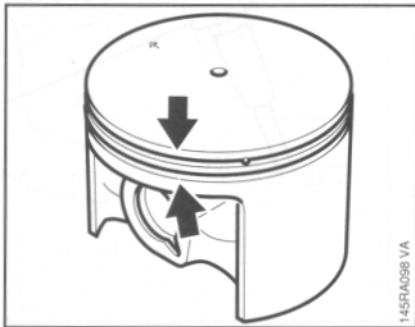

- Use a piece of old piston to scrape the grooves clean.

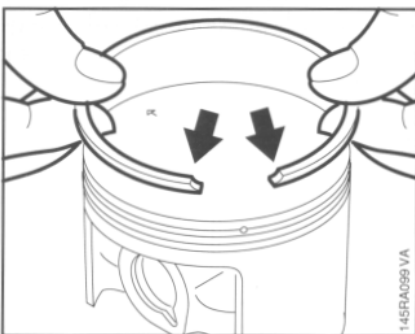

- Install the new piston rings in the grooves so that the radii face upward.
- Install the piston - see 4.5.2.

4.7 Crankcase

4.7.1 Removing the Crankshaft

- Remove the clutch - see 3.2.
- Remove the chain brake - see 3.3.1.
- Remove the cylinder - see 4.5.1.
- Remove the flywheel - see 5.3.
- Drain the oil tank.
- Drain the fuel tank.

Note: Dispose of fuel at approved disposal site.

- Remove the oil pump - see 9.4.1.

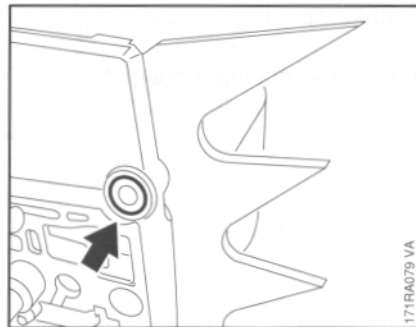

- Hold the self-locking nut steady and take out the screws.

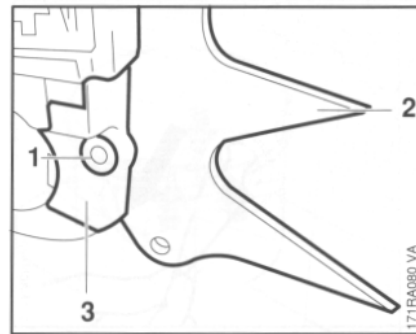

- Take out the screw (1).
- Remove the spiked bumper (2) with deflector (3).

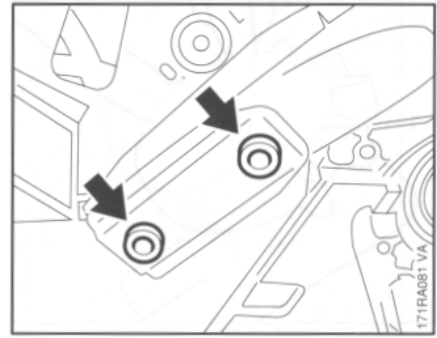

Important: Heat the screws. Take care not to overheat plastics.

- Remove front handle mounting screws from side of machine.

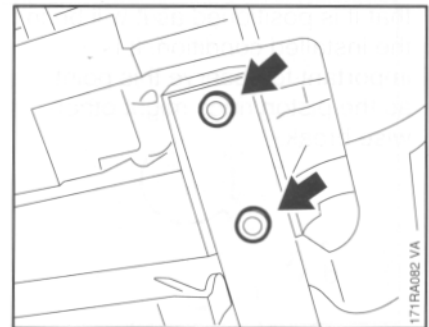

- Remove front handle mounting screws from underside of machine.

- Lift away the front handle.

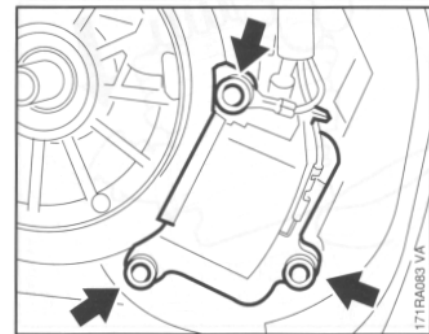

- Take out the screws.
- Remove the ignition module.

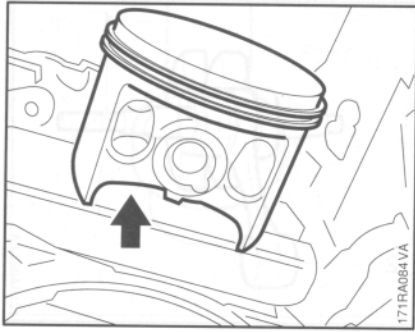

- Remove the piston - see 4.5.1.

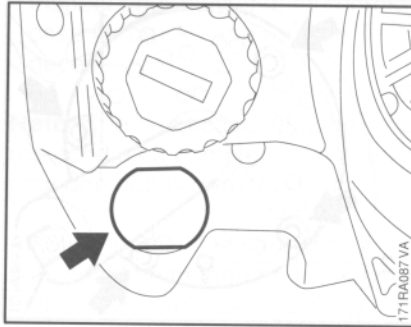

- Pry the plug out of the annular buffer at the starter side.

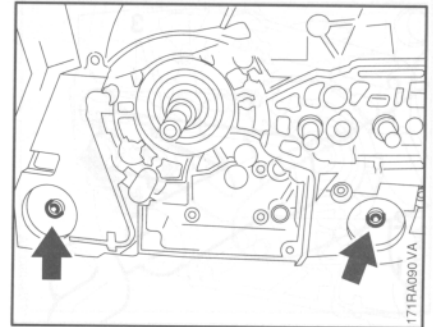

- Take the screws out of the annular buffers.
- Lift the crankcase away from the tank housing.

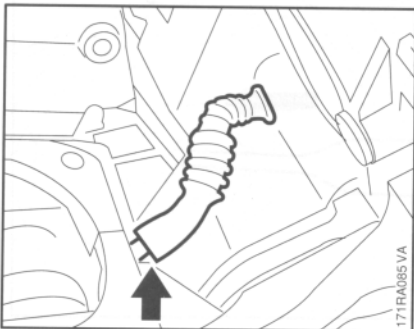

- Pull impulse hose off the nipple.

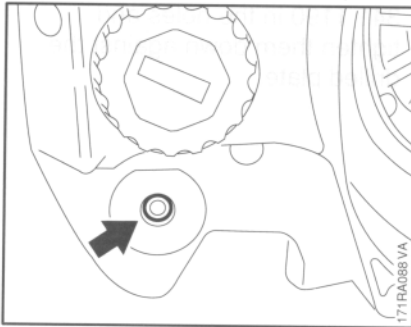

- Take the screw out of the annular buffer.

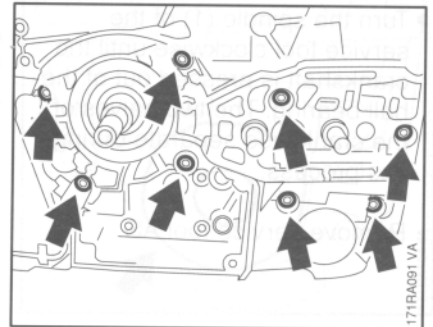

- Unscrew the mounting screws which join the two halves of the crankcase.

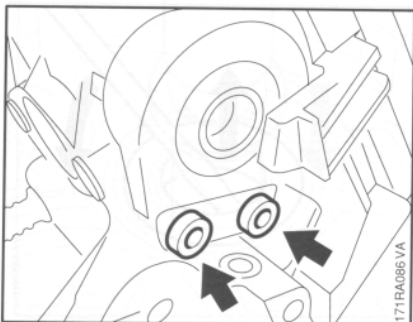

- Take out the screws.

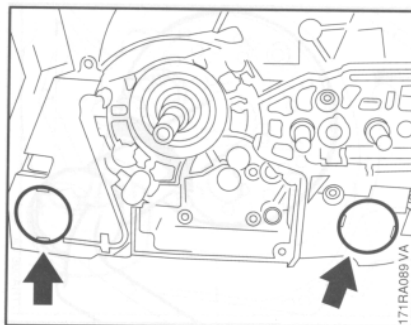

- Pry the plugs out of the annular buffers at the clutch side.

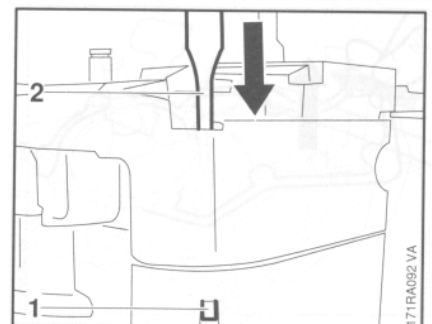

- At chain tensioner side of crankcase, use a 5 mm (3/16") drift (2) to drive the dowel pin (1) out of the two halves of the crankcase.

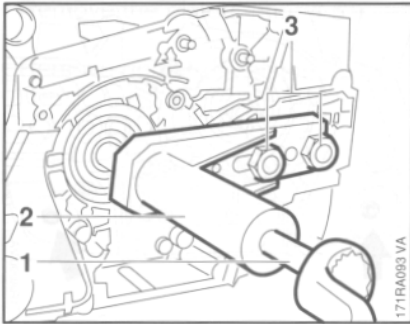

- Back off spindle (1) of service tool AS 5910 007 2205 all the way.
- Slip service tool AS (2) over the collar studs, fit the hexagon nuts (3) (for sprocket cover) and tighten them down by hand.
- Turn the spindle (1) of the service tool clockwise until the crankshaft is pressed out of the ball bearing. The two halves of the crankcase separate during this process.
- Remove service tool AS.

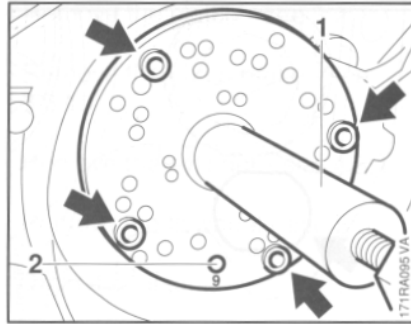

- Fit service tool ZS (1) 5910 007 2220 against starter side of crankcase so that number "9" (2) on the plate is at the bottom.

Note: Cylinder flange upright.

Insert four M5x72 screws 9022 341 1190 in the holes and tighten them down against the drilled plate.

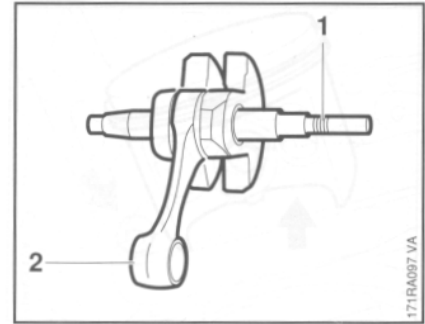

- The crankshaft (1), connecting rod (2) and needle bearing form an inseparable unit. This means that the crankshaft must always be replaced as a complete unit.
- When fitting a replacement crankshaft, always install new oil seals and ball bearings.

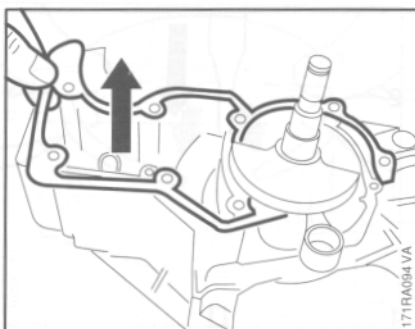

- Remove crankcase gasket.
- Unscrew spindle of service tool ZS a little (left-hand thread).

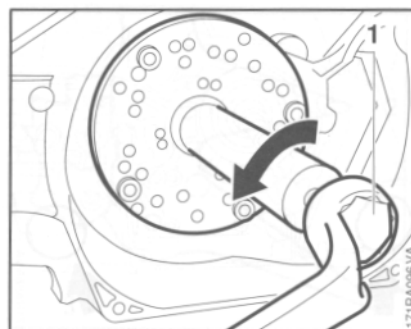

- Turn spindle (1) counterclockwise until the crankshaft is pushed out of the ball bearing.

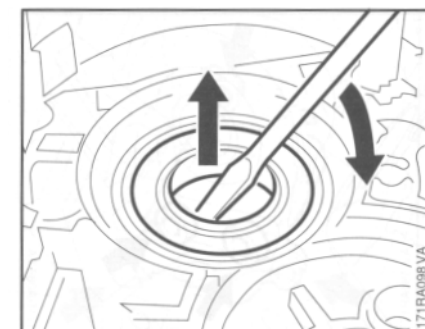

- Pry the oil seal out of the ball bearing at the clutch side.

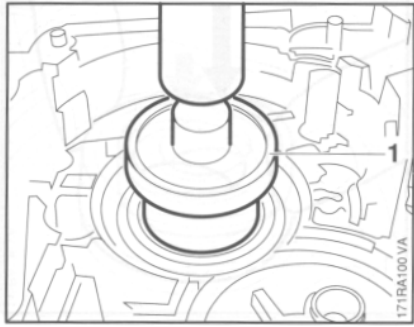

- Use press arbor (1) 1124 893 7200 to press the ball bearing out of its seat.
- If necessary, remove snap ring from bearing seat.

- Inspect both halves of the crankcase for cracks and replace if necessary.

Note: The crankcase must be replaced as a complete unit even if only one half is damaged.

All other parts which are still serviceable can then be transferred to the new crankcase.

If only the ball bearings have to be replaced, remove all rubber and plastic components first, i.e. oil suction hose, stop buffer and annular buffers. Carry out the following operations for this purpose.

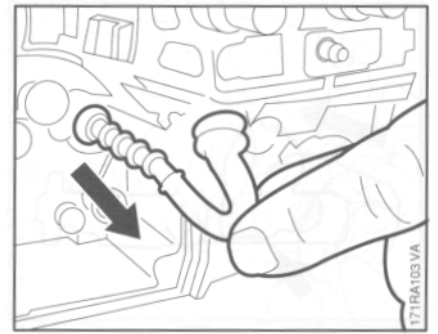

- Pull out the oil suction hose with pickup body.

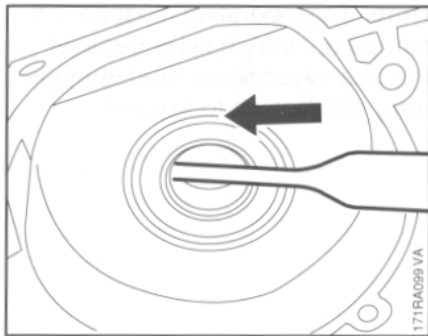

- Carefully knock the oil seal out of the starter side of the crankcase.

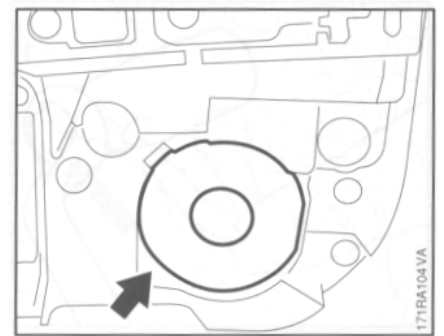

- Push the annular buffer out of the clutch side of the crankcase.

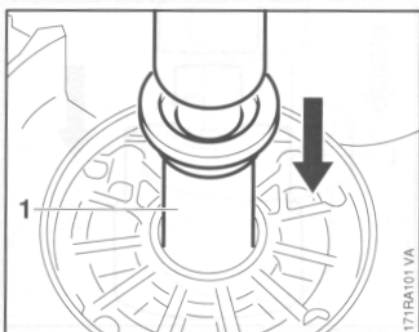

- Use press arbor (1) 1119 893 2401 to remove the ball bearing.

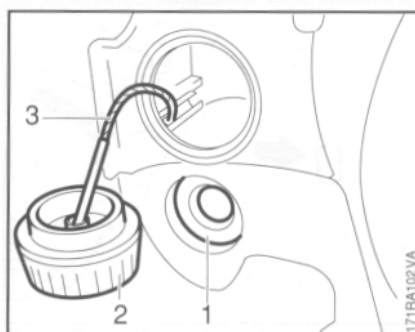

- Push the annular buffer (1) out of the starter side of the crankcase.
- Unscrew the oil tank filler cap (2).
- Remove cord (3) from the groove.

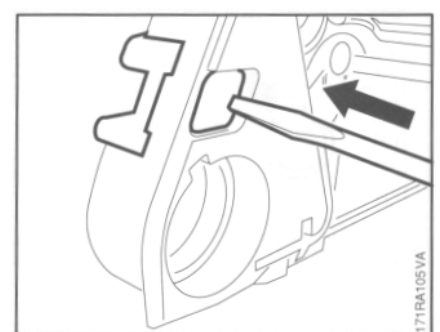

- Push the stop buffer out of its seat.

Note: To replace the crankcase, carry out the following operations.

4.7.2 Installing the Crankshaft

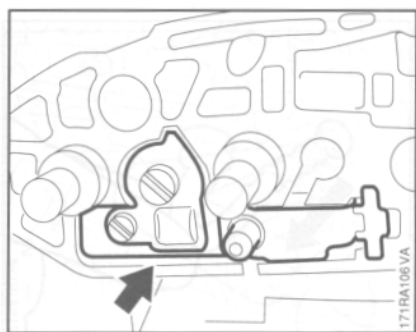

New crankcases come with preassembled ball bearings.

Stamp the machine number on the crankcase with 2.5 mm (0.1 ") figure stamps.

If the original crankcase is used again, remove the gasket residue and clean the mating surfaces they must be cleaned very thoroughly to ensure a perfect joint.

- Remove the complete chain tensioner - see 3.4.

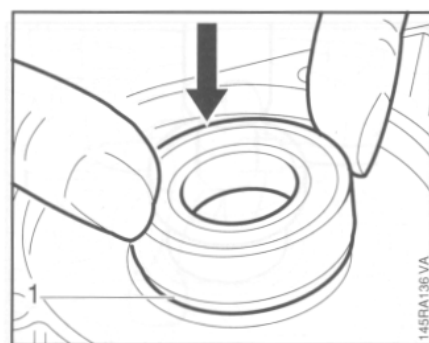

- Heat area of bearing seat on clutch side of crankcase to approx. 150 C (300 F).

- Place ball bearing in position, with stepped edge (1) down, and push it home by hand as far as stop.

Note: This operation must be carried out very quickly because the bearing absorbs heat immediately and begins to expand.

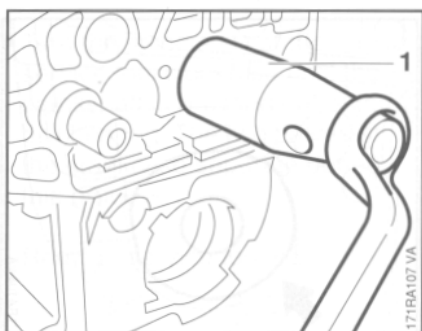

- If necessary, use stud puller (1) 5910 893 0506 to unscrew the collar studs.

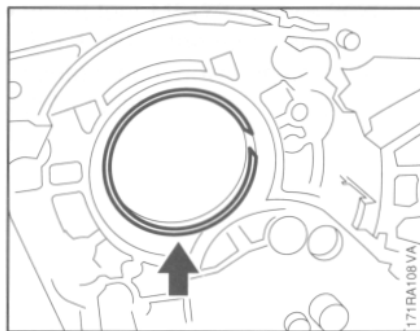

- Check that snap ring is fitted in the clutch side of the crankcase.

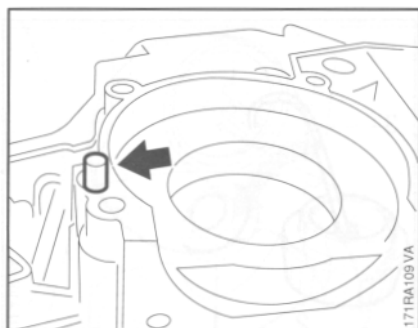

- Check that dowel pin is in position. If necessary, drive dowel pin into new crankcase.

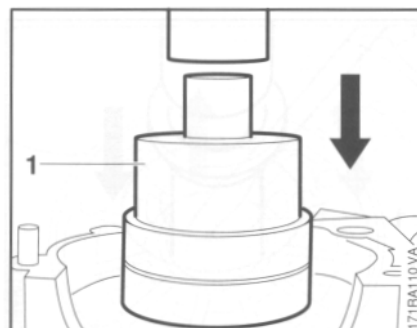

- If it is not possible to heat the crankcase, use the press arbor (1) 1124 893 7200 to press in the ball bearing as far as stop.

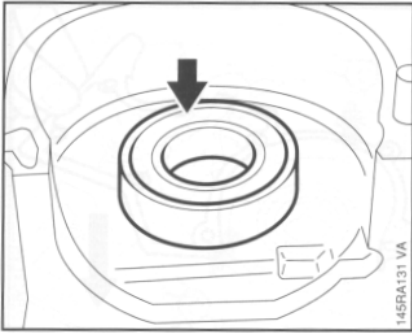

- Heat area of bearing seat on starter side of crankcase to approx. 150° C (300°F).
- Place ball bearing in position (closed side up) and push it home by hand as far as stop.

Note: This operation must be carried out very quickly because the bearing absorbs heat immediately and begins to expand.

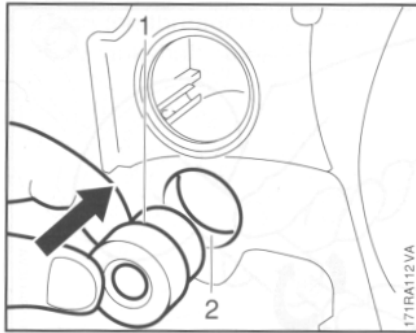

- After the crankcase has cooled down, push the annular buffer into position until its annular groove (1) engages the edge of the housing (2).

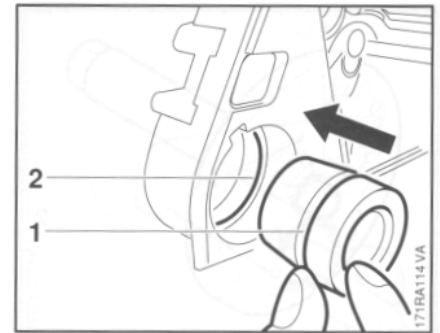

- Push the two annular buffers, tapered end first, into position until their annular grooves (1) engage the edge of the housing (2).

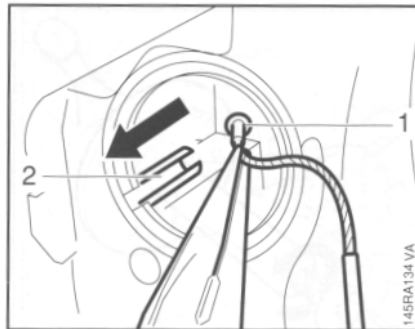

- Place filler cap's cord (1) in the groove (2) and pull it forward.

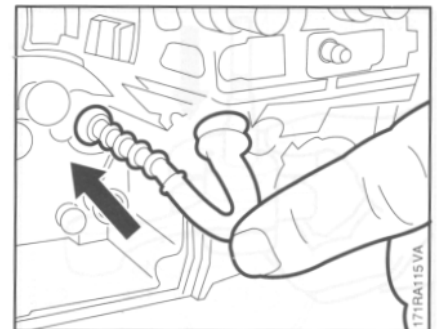

- Push the oil suction hose into the crankcase bore.

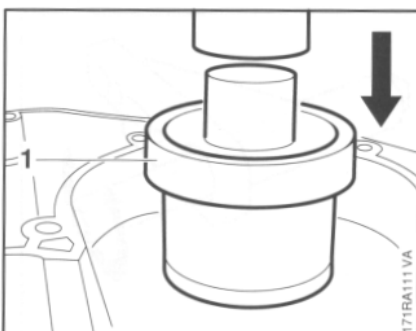

- If it is not possible to heat the crankcase, use the press arbor (1) 1124 893 7200 to press in the ball bearing as far as stop.

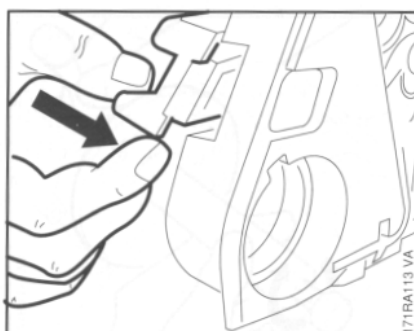

- After the crankcase has cooled down, push the stop buffer into guide until its lugs are behind the edge of the housing.

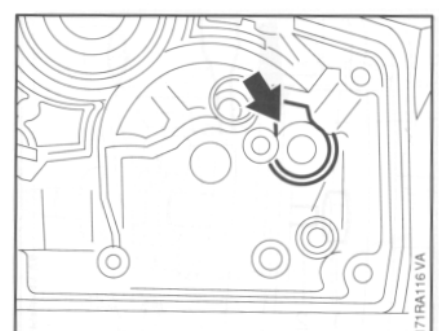

- Use a blunt tool to push the oil suction hose into the bore so that its tab locates in the recess at the top left.

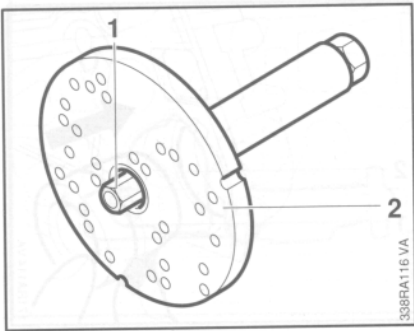

- Screw the spindle fully into service tool ZS (2) and then screw the threaded sleeve (1) 5910 893 2421 onto the spindle as far as it will go.

- Lubricate tapered crankshaft stub with oil.

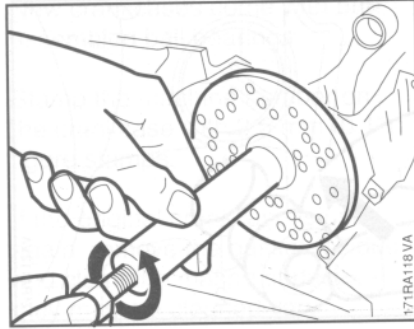

- Hold the spindle steady and turn the service tool counter-clockwise until the drilled plate butts against the crankcase.

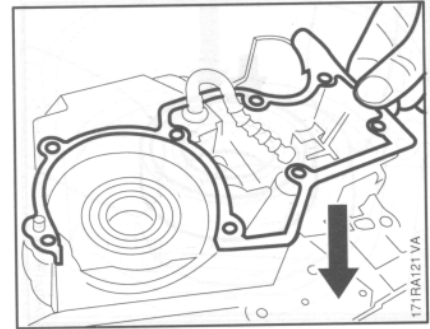

- Fit a new gasket on the clutch side of the crankcase.

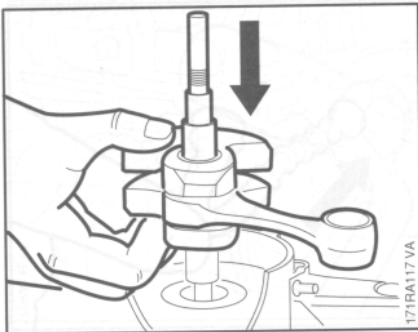

- Place tapered crankshaft stub in ball bearing at starter side of crankcase.

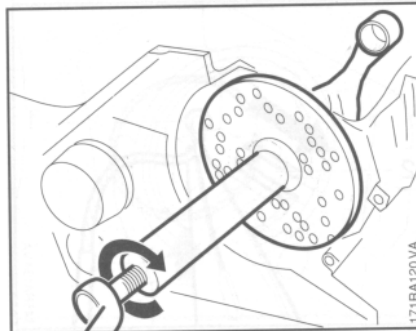

- Turn the spindle clockwise until the crankshaft locates against the ball bearing.

Important: The connecting rod must point toward the cylinder flange while the crankshaft is being installed.

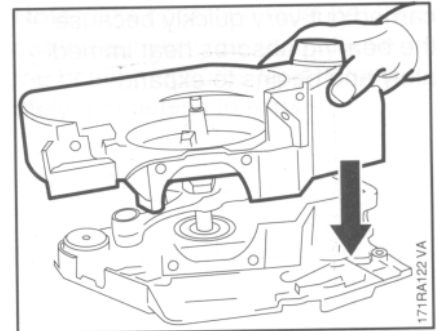

- Lubricate straight crankshaft stub with oil.
- Position crankshaft stub in ball bearing.

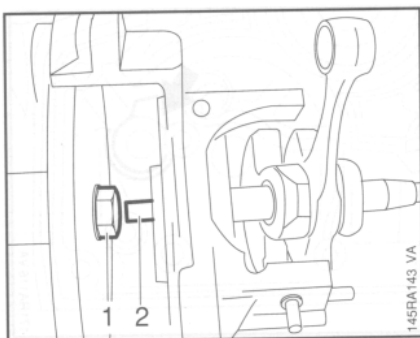

- Apply threaded sleeve (1) to thread (2) on crankshaft stub and screw it on.

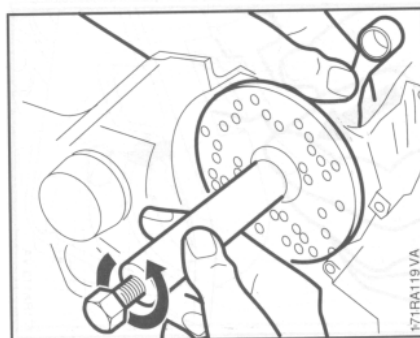

- Release the spindle by turning it counter-clockwise and then hold the crankshaft steady and unscrew the service tool counter-clockwise.

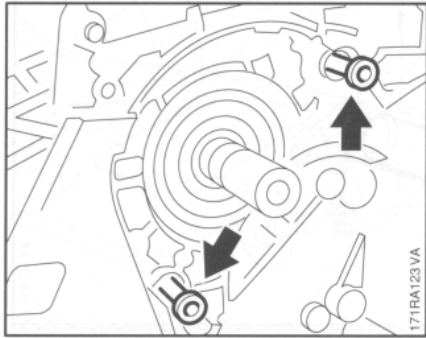

- Push the threaded sleeve over the crankshaft stub.

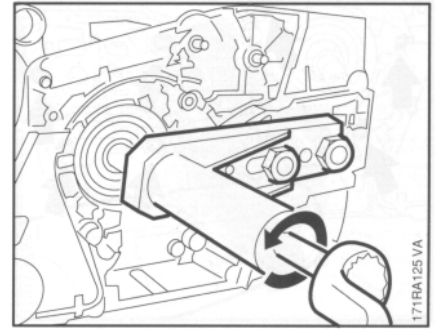

- Turn the spindle counterclockwise until the crankshaft locates against the ball bearing.

- To prevent the crankcase and gasket twisting, fit M5x72 screws (from service tool ZS) in two crankcase holes as far as stop.

- Unscrew the hexagon nuts.
- Unscrew the spindle clockwise and take away the service tool.
- Take out the two M5x72 screws.

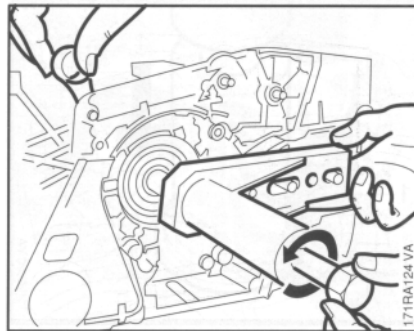

- Hold the crankshaft steady, rotate the spindle counterclockwise to screw the threaded sleeve onto the crankshaft.

- Screw the spindle fully into service tool AS by turning it clockwise.

- Release the crankshaft. Hold the service tool steady and continue turning the spindle until the tool locates against the guide bar mounting face.

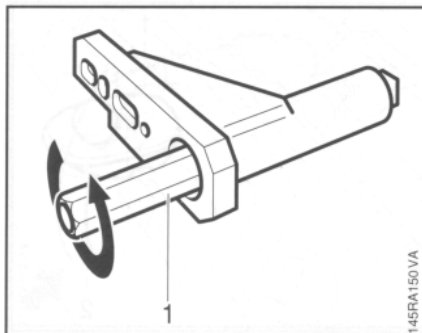

- Fit two hexagon nuts on the bar mounting studs and screw them down fingertight.

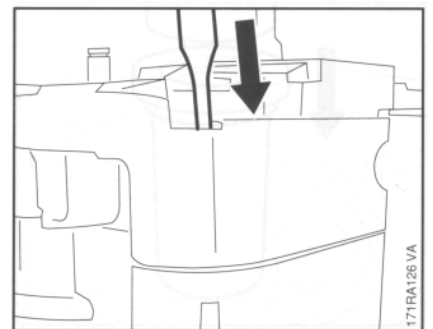

- Screw threaded sleeve (1) 5910 893 2408 onto the spindle as far as it will go (left-hand thread).

- Use a 5 mm (3/16") drift to drive the dowel pin into the two halves of the crankcase from the sprocket side.

4.8 Decompression Valve

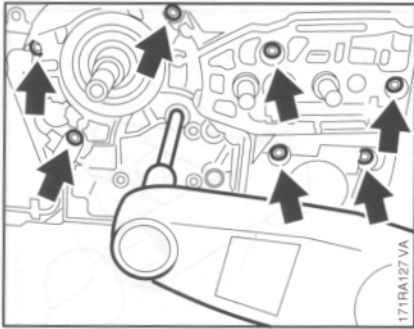

- Fit screws and tighten them down alternately in a diagonal pattern to 11.5 Nm (8.5 lbf.ft).

Note: Trim away any excess gasket material in the area of the cylinder mounting face.

- Coat sealing lips of oil seals with grease - see 11.2.
- Apply thin coating of sealant, see 11.2, to outside diameter of oil seals.
- Slide the oil seal, open side facing the crankcase, over the ignition end of the crankshaft.

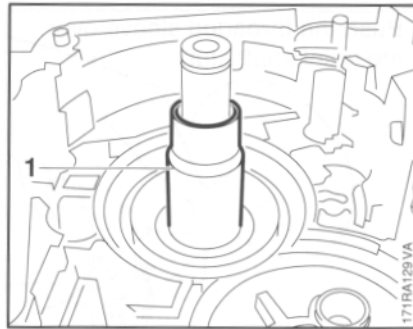

- Fit the assembly sleeve (1) 1124 893 4600 over the clutch end of the crankshaft.

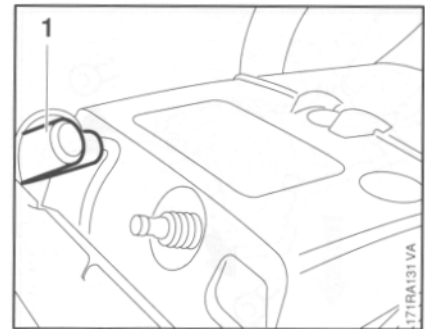

- Remove carburetor box cover - see 10.1.
- Pull off the spark plug boot (1).

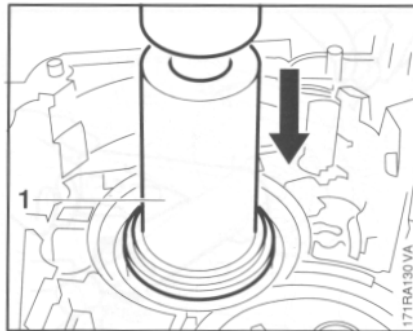

- Slide the oil seal, open side facing the crankcase, over the assembly sleeve.
- Press it home with press sleeve (1) 1127 893 2400.
- Remove the assembly sleeve.
- Wait about one minute, then turn the crankshaft several times.

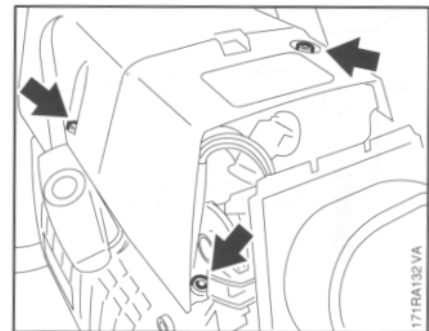

- Take out the shroud mounting screws.
- Lift away the shroud.

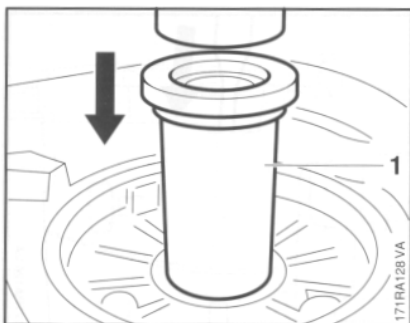

- Press it fully home with press sleeve (1) 1127 893 2400.

Note: The press surface must be flat and free from burrs.

Assembly of the remaining parts is a reversal of the disassembly sequence.

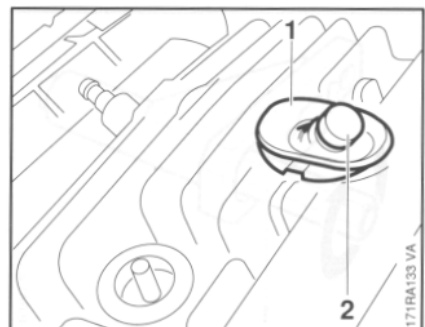

- Remove the grommet (1).
- Unscrew the decompression valve (2).

5. IGNITION SYSTEM

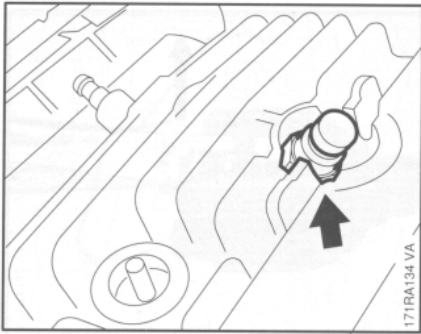

- Fit new decompression valve and torque down to 14 Nm (10.3 lbf.ft).

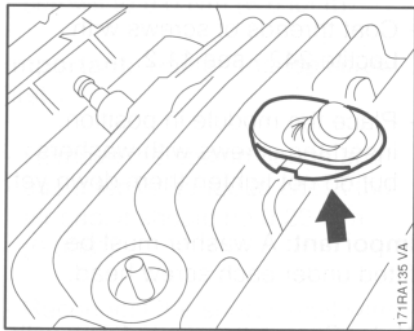

- Fit the grommet and check that it is properly seated.

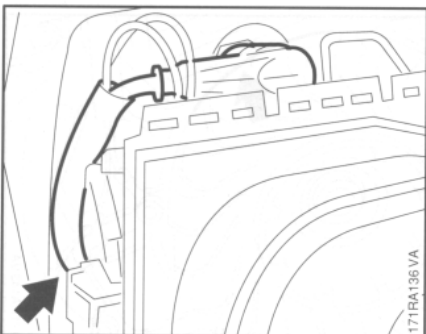

- Fit the shroud and make sure the ignition lead is correctly positioned in the shroud recess.

Reassemble all other parts in the reverse sequence.

Warning! Exercise extreme caution when carrying out maintenance and repair work on the ignition system. The high voltages which occur can cause serious or even fatal accidents!

Troubleshooting on the ignition system should always begin at the spark plug. See "Standard Repairs. Troubleshooting" handbook.

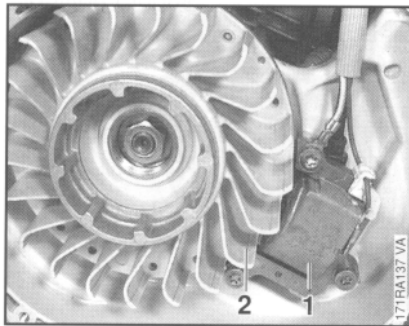

Note: The electronic (breakerless) ignition system basically consists of an ignition module (1) and flywheel (2) and is easily accessible.

5.1 Ignition Module

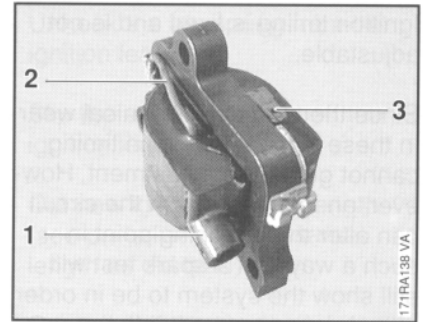

The ignition module accommodates all the components required to control ignition timing. There are three electrical connections on the coil body:

1. the high voltage output (1)
2. the ground wire (2)
3. the connector tag (3) for the short circuit wire

Accurate testing of the ignition module is only possible with sophisticated test equipment. For this reason it is only necessary to carry out a spark test in the workshop. A new ignition module must be installed if no ignition spark is obtained (after checking that wiring and stop switch are in good condition).

5.1.1 Ignition Timing

Ignition timing is fixed and is not adjustable.

Since there is no mechanical wear in these systems, ignition timing cannot get out of adjustment. However, an internal fault in the circuit can alter the switching point in such a way that a spark test will still show the system to be in order although timing is outside the permissible tolerance. This will impair engine starting and running behavior.

5.1.2 Removing and Installing

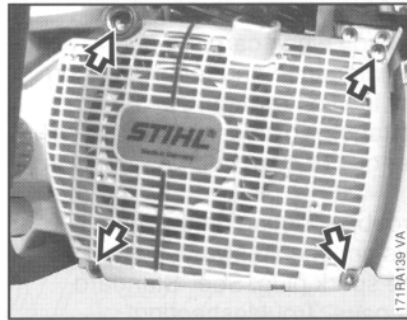

- Remove carburetor box cover .- see 10.1.
- Remove the shroud - see 4.8.
- Take out the screws.
- Remove the fan housing.

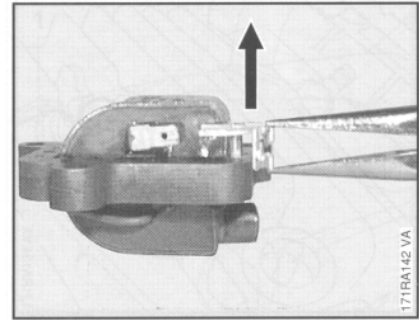

- If necessary, pry the pin of the wire retainer out of the ignition module.
- Remove wire retainer.
- Refit retainer before installing the ignition lead - see 5.2.
- Coat threads of screws with
- Loctite 242 - see 11.2.
- Place the module in position, insert the screws with washers but do not tighten them down yet.

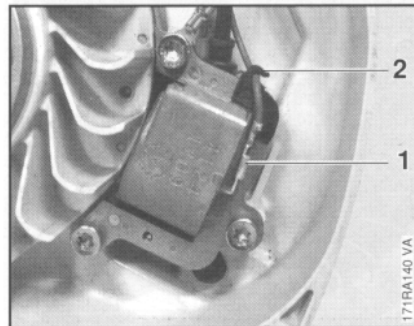

- Pull the short circuit wire (1) off the connector tag on the ignition module and out of the retainer (2).

Important: A washer must be fitted under each screw head.

Note: Secure the ground wire with the upper mounting screw.

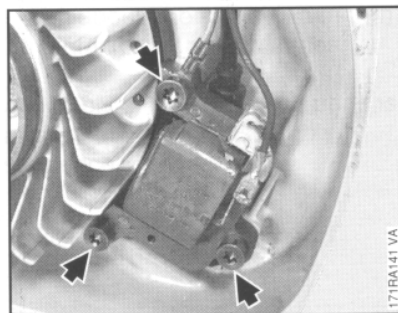

- Take out the screws.
- Remove the ignition module.
- Remove the ignition lead - see 5.2.



- Rotate the flywheel until the magnets are between the arms of the ignition module.

5.2 Spark Plug Boot/ Ignition Lead

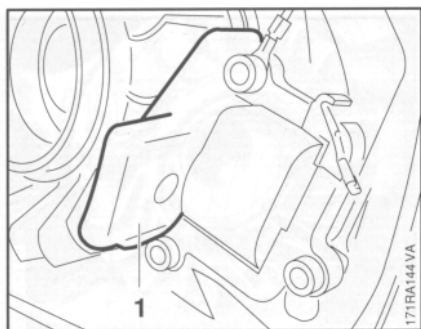

- Slide the setting gauge (1) 1111 890 6400 between the arms of the ignition module and the raised edge of the flywheel.
- Press the ignition module against the setting gauge and tighten down the mounting screws to 9.0 Nm (6.6 lbf.ft).

Important: Tighten the top screw first.

- Remove the setting gauge and use a feeler gauge to check the air gap. It should be 0.20 mm (0.008").
- Reconnect the short circuit wire.
- Fit the fan housing, tighten screws to 7.0 Nm (5.2 lbf.ft).
- Install the shroud - see 4.8.
- Fit the carburetor box cover - see 10.1.

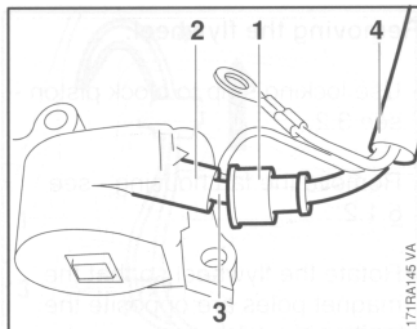

- Remove the ignition module - see 5.1.2.
- Pull the grommet (1) off the high voltage output (2).
- Unscrew the lead (3) from the contact pin and pull it out of the ignition module.
- Pull grommet and insulating tube (4) off the ignition lead.

- Unhook the leg spring from the ignition lead.
- Slip the spark plug boot off the ignition lead.
- Cut new ignition lead to length (see parts list or cut to same length as old lead).
- Coat end of the ignition lead (about 20 mm/3/4") with oil.
- Fit spark plug boot over the ignition lead.
- Use suitable pliers to grip the end of the ignition lead inside the spark plug boot and pull it out.

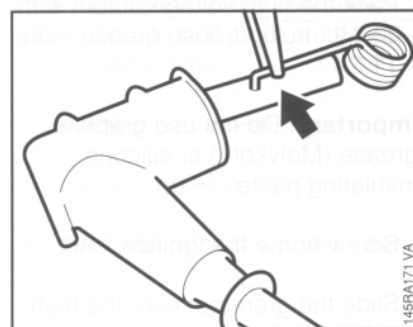

- Pinch the hook of the leg spring into the center of the lead, i.e. about 15 mm (5/8") from the end of the lead.

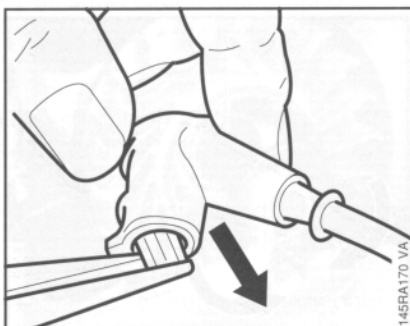

- Use suitable pliers to grip the leg spring and pull it out of the spark plug boot.

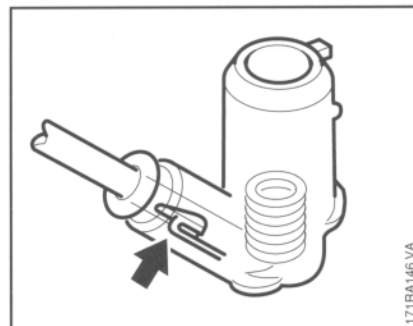

- Pull the lead back into the boot so that the leg spring locates properly inside it.

5.3 Flywheel

Removing the flywheel:

- Use locking strip to block piston - see 3.2.
- Remove the fan housing – see 5.1.2.
- Rotate the flywheel so that the magnet poles are opposite the ignition module.

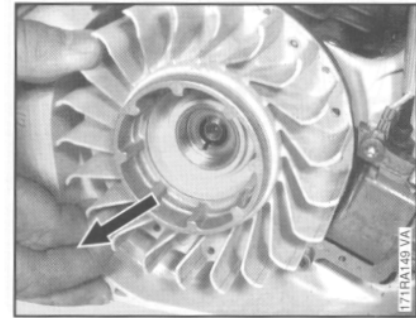

- Pull off the flywheel.

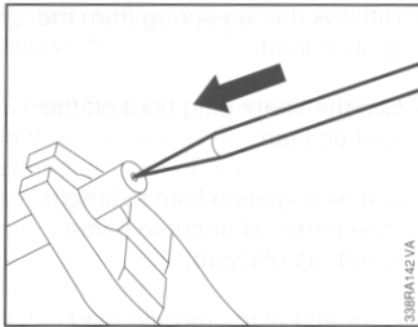

- Use a pointed tool (awl or gimlet) to pierce the center of the other end of the ignition lead which screws into the module.
- Slip the insulating hose and grommet onto the lead.
- Pack the high voltage output with STIHL multipurpose grease - see 11.2.

Important: Do not use graphite grease (Molykote) or silicone insulating paste.

- Screw home the ignition lead.
- Slide the grommet over the high voltage output.
- Install the ignition module – see 5.1.2.

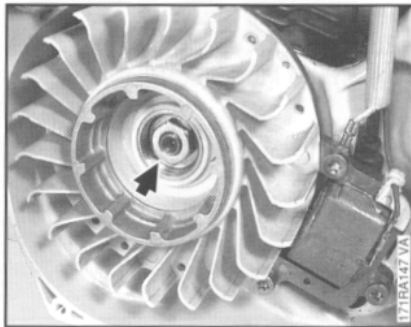

- Unscrew the flywheel nut.

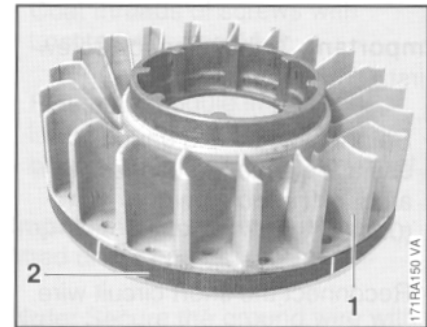

Inspect flywheel (1) and magnets (2). If you find any damage (e.g. cracks, broken fan blades), fit a new flywheel.

Installing the flywheel:

Important: Clean the stub of the crankshaft and the flywheel hub bore with a standard commercial, solvent-based degreasant containing no chlorinated or halogenated hydrocarbons -see 11.2.

- Fit the flywheel in position.
- Fit and tighten down flywheel nut to 45 Nm (33.0 lbf.ft).

Assembly of the remaining parts is now a reversal of the disassembly sequence.

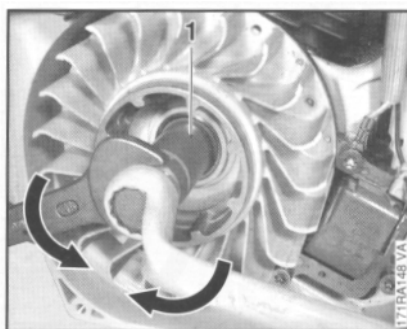

- Screw the puller (1) 1106 890 4501 into the flywheel.
- Screw home the thrust bolt until the flywheel is released.

5.4 Ground Wire/Short Circuit Wire

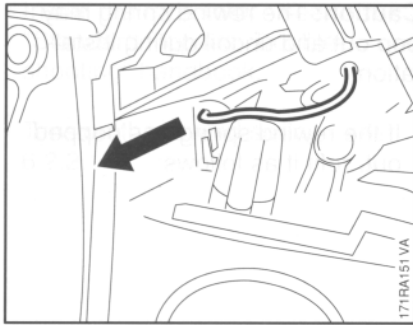

- Remove the filter base - see 10.1.
- Remove the shroud - see 4.8.
- Pull the ground wire (1) out of the contact spring.

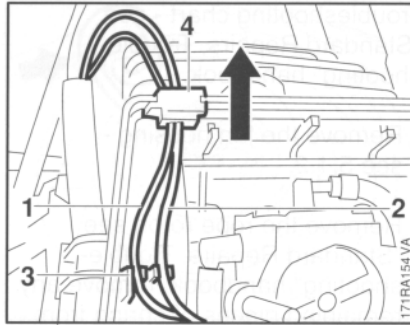

- Pull short circuit wire (1) and ground wire (2) out of retainer (3) and the upper grommet (4).
- Remove the fan housing - see 5.1.2.

5.5 Contact Spring

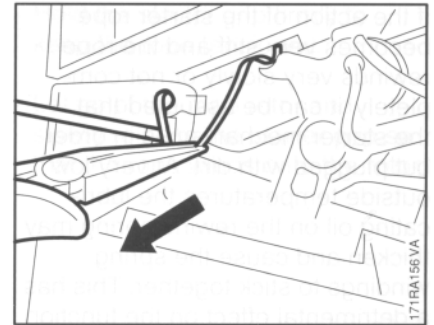

- Remove carburetor box cover - see 10.1.
- Pull ground wire out of contact spring - see 5.4.
- Use a small screwdriver to ease the contact spring off the lug in the tank housing and use suitable pliers to pull it out of its seat at the same time.

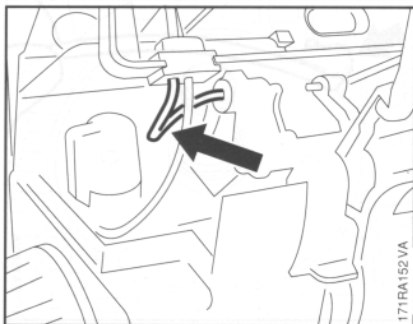

- Pull the short circuit wire out of the switch shaft.

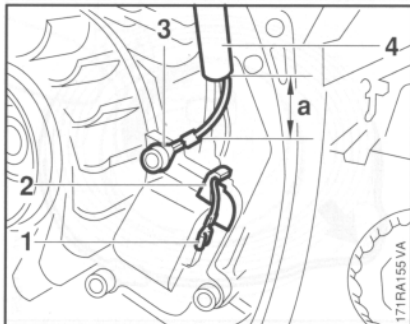

- Pull short circuit wire (1) off the tag on the ignition module and ease it out of the retainer (2).
- Take out the screw.
- Remove the ground wire (3).
- Pull short circuit and ground wires out of the insulating tube (4).

- Install new contact spring.
- Fit the ground wire.
- Fit the carburetor box cover - see 10.1.

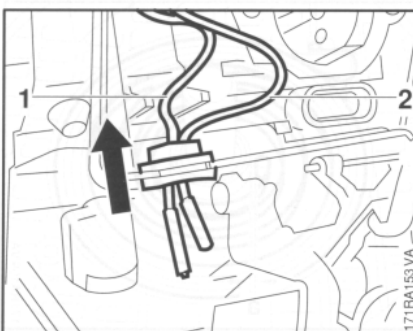

- Pull short circuit wire (1) and ground wire (2) out of lower grommet.

Reassemble in the reverse sequence.

- Check that upper and lower grommets are properly seated.
- Distance "a" between terminal and insulating tube should be 15 mm (0.6 in).

6. REWIND STARTER
6.1. General

If the action of the starter rope becomes very stiff and the rope rewinds very slowly or not completely, it can be assumed that the starter mechanism is in order but plugged with dirt. At very low outside temperatures the lubricating oil on the rewind spring may thicken and cause the spring windings to stick together. This has a detrimental effect on the function of the starter mechanism. In such a case it is sufficient to apply a few drops of paraffin (kerosine) to the rewind spring.

Then carefully pull out the starter rope several times and allow it to rewind until its normal smooth action is restored.

If clogged with dirt or pitch, the entire starter mechanism, including the rewind spring, must be removed and disassembled. Take special care when removing the spring.

Wash all parts in paraffin or white spirit.

Lubricate the rewind spring and starter post with STIHL special lubricant, see 11.2, before installing.

6.2 Rewind Spring
6.2.1 Replacing

Troubleshooting chart
 - see "Standard Repairs. Troubleshooting" handbook.

- Remove the fan housing
 - see 5.1.2.
- Remove the rope rotor, see "Standard Repairs. Troubleshooting" handbook, remove any remaining pieces of spring from the fan housing.

Caution: The rewind spring may pop out and uncoil during installation.

- If the rewind spring has popped out, refit it as follows:

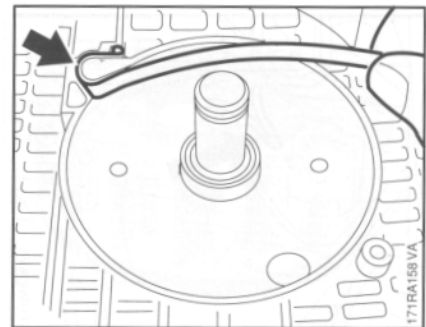
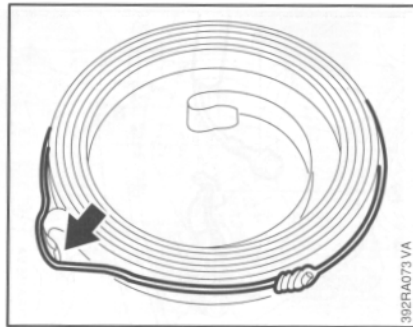

Note: The replacement spring comes ready for installation and is held by a wire retainer. It should be lubricated with a few drops of STIHL special lubricant before installation - see 11.2.

- Engage the outer anchor loop in the recess and then fit the spring in the clockwise direction in the fan housing, starting outside and working inwards.

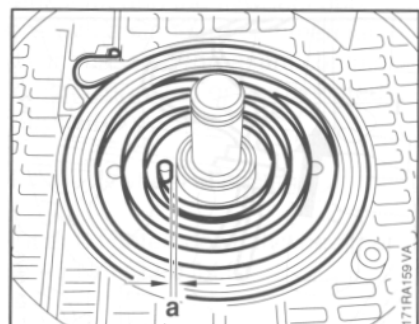
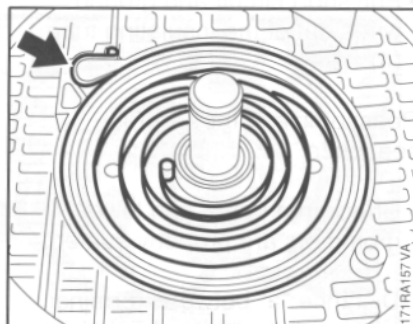

- Fit the rewind spring so that its outer anchor loop engages the recess in the fan housing. The wire retainer slips off as the spring is pressed into place.

- Check position of inner spring loop relative to bore, i.e. "a" = 2 mm (0.08 in), and correct if necessary.

6.2.2 Tensioning

- Install the rope rotor - see "Standard Repairs, Troubleshooting" handbook.
- Tension the rewind spring - see 6.2.2.

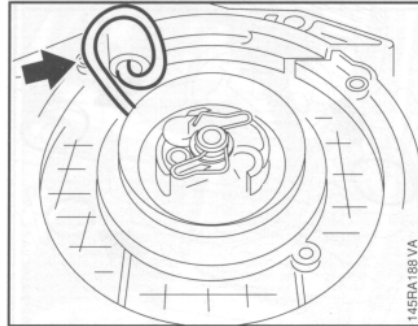

- Hold the starter grip firmly to keep the rope tensioned.
- Let go of the rope rotor and slowly release the starter grip so that the rope winds onto the rotor.

- Make a loop in the starter rope.

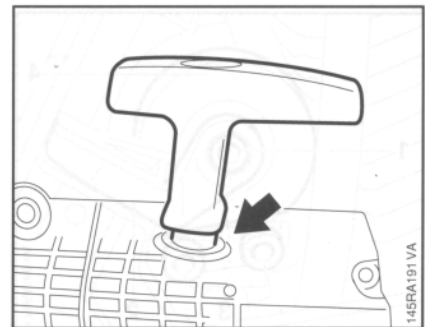
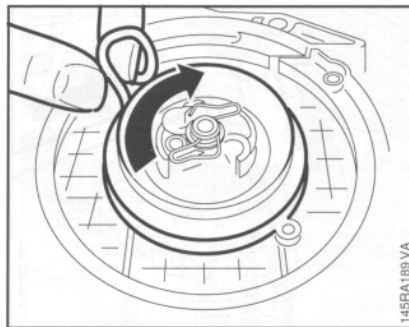

- Grip the rope **close** to the rotor and use it to turn the rope rotor six full turns clockwise.

Note: The rewind spring is correctly tensioned when the starter grip sits firmly in the rope guide bush without drooping to one side. If this is not the case, tension the spring by one additional turn.

When the starter rope is fully extended, it must still be possible to rotate the rope rotor at least another half turn before maximum spring tension is reached. If this is not the case, pull the rope out, hold the rope rotor steady and take off one turn of the rope.

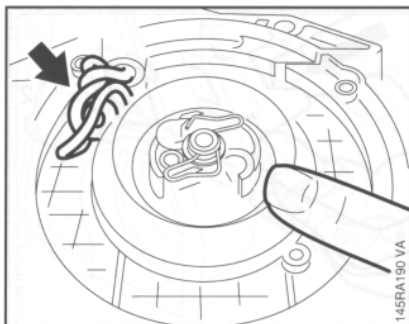

Do not overtension the rewind spring - it might break.

- Refit the fan housing - see 5.1.2.

- Hold the rope rotor steady.
- Pull out the rope with the starter grip and straighten it out.

7. AV HANDLE SYSTEM

Rubber anti-vibration buffers are installed between the engine housing and handle frame. Damaged rubber buffers (annular buffers) must always be replaced.

- Remove the shroud - see 4.8.

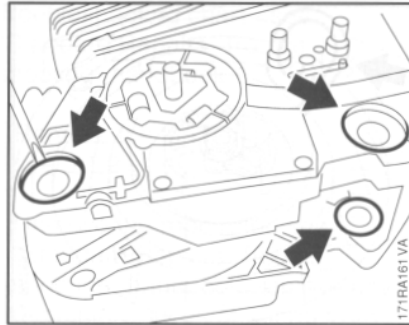

- Pry the annular buffers out of the crankcase.

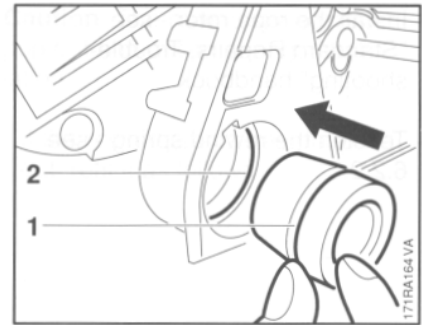

- At clutch side, push annular buffer home from outside until its groove (1) engages the housing rib (2).

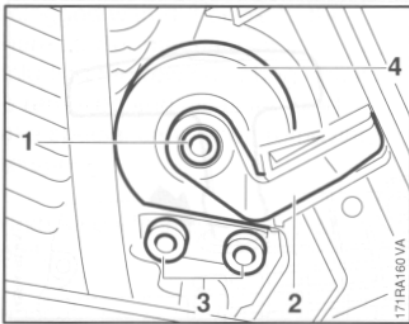

- Take out the center screw (1).
- Remove the support (2).
- Take out the screws (3).
- Remove the annular buffer (4).

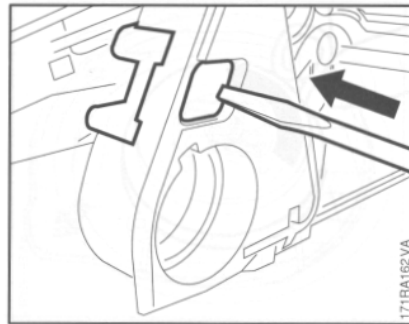

- Push the stop buffer out of its seat and take it away.

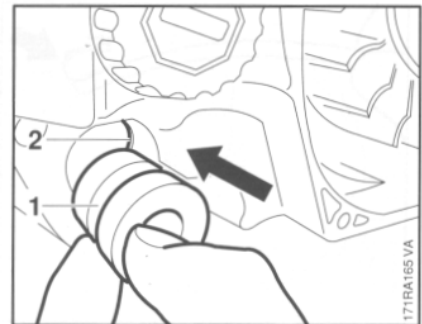

- At the starter side, push annular buffer home from outside until its groove (1) engages the housing rib (2).

Assembly is now a reversal of the disassembly sequence.

Note: Remove the tank housing, see 10.6, for access to the other annular buffers.

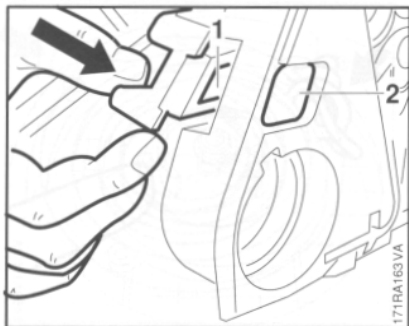

- Push the stop buffer into the guide until the groove (1) engages the housing rib (2).

8. MASTER CONTROL/HANDLE SYSTEM

8.1 Switch Shaft

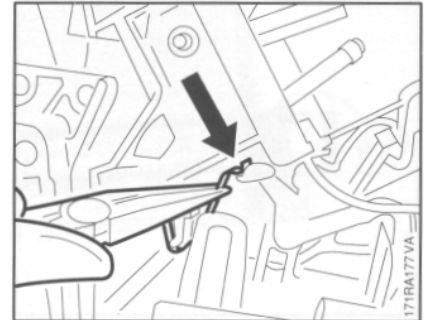
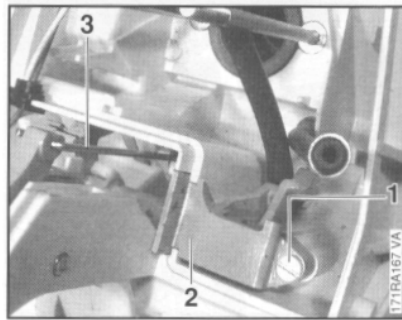
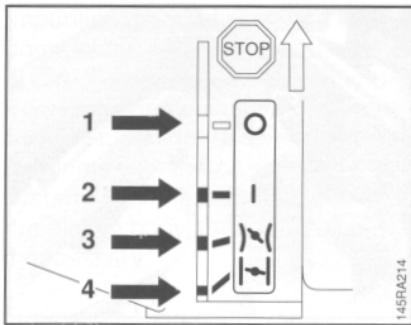

The thumb-operated Master Control lever moves the switch shaft to select the required function.

The following positions can be selected with the Master Control lever:

- STOP (1) (closes short circuit contact and interrupts ignition)
- RUN (2) (normal operating position)
- START (3) (warm start - starting throttle/ choke shutter open)
- CHOKE (4) (cold start - starting throttle/ choke shutter closed)

- Remove throttle rod from carburetor - see 10.2.1.

- Take out the screw (1).
- Remove the right-hand pivot mount (2).
- Disconnect the throttle rod (3).

Reassemble in the reverse sequence.

Hold the contact spring up while installing the switch shaft.

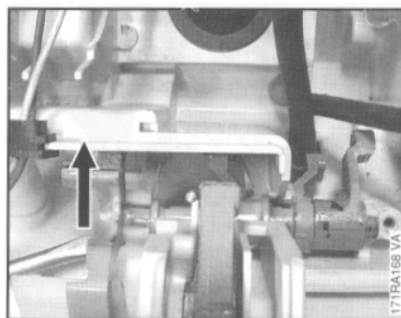

- Ease the switch shaft out of its left-hand pivot mount.
- Remove the switch shaft.

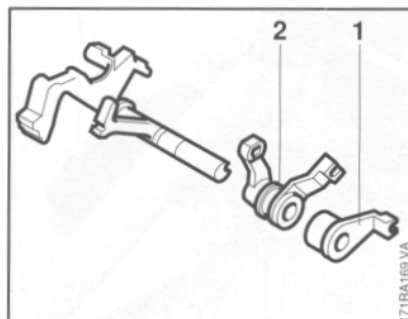
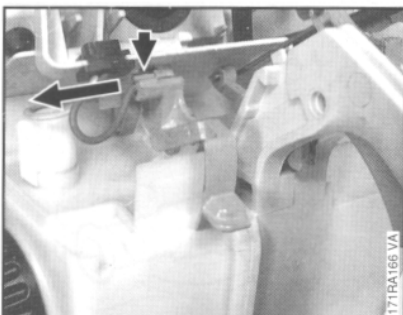

• Pull short circuit wire out of the switch shaft.

- Remove the choke lever (1) and double lever (2).

8.2 Throttle Trigger/Interlock Lever

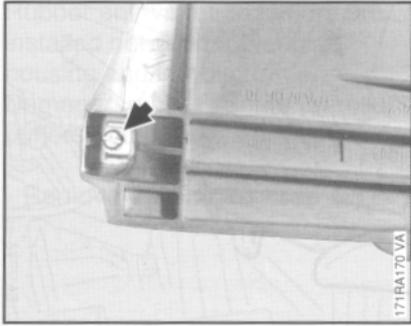

- Remove the filter base - see 10.1.
- Take out the screw.
- Remove the handle molding.

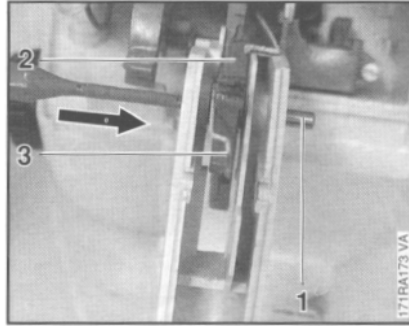

- Use a 5 mm (3/16") drift to drive out the dowel pin (1).
- Take out the throttle trigger (2) with torsion spring (3).

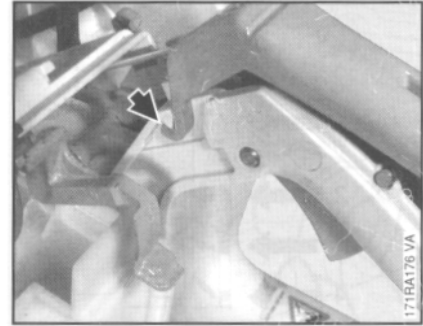

- Fit the handle molding and make sure it engages properly.
- Fit the filter base - see 10.1.

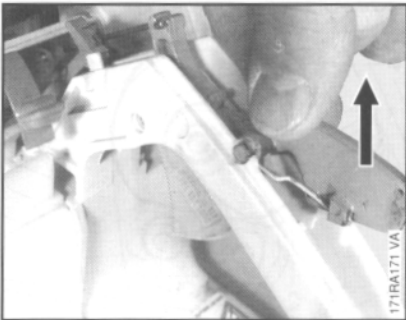

- Move Master Control lever to "Run" position.
- Take out the interlock lever.

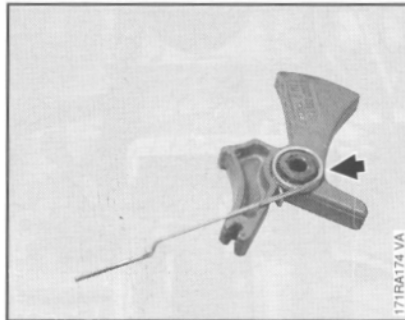

- Remove the torsion spring from the throttle trigger.
- The torsion spring must be fitted under the interlock lever and locate in the notch.

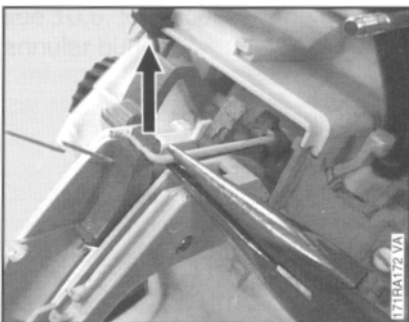

- Pull the throttle rod out of the throttle trigger.

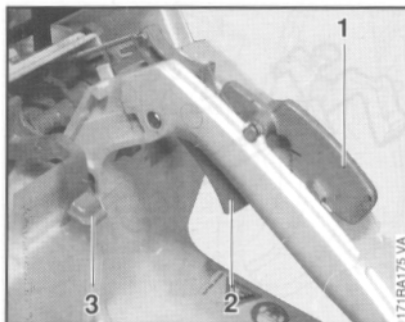

- Press the interlock lever (1) down.
- Pull the throttle trigger (2) up and move the Master Control lever (3) to "Choke".

9. CHAIN LUBRICATION

9.1 Pickup Body/Suction Hose

Impurities gradually clog the fine pores of the filter with tiny particles of dirt. This prevents the oil pump from supplying sufficient oil to the bar and chain. In the event of problems with the oil supply system, first check the oil tank and the pickup body. Clean the oil tank if necessary.

Troubleshooting chart - see "Standard Repairs, Troubleshooting" handbook.

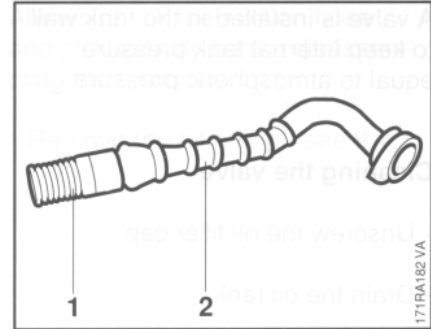
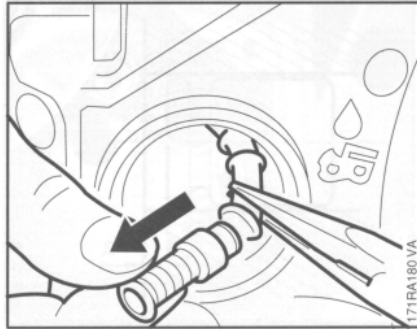

- Pull the pickup body out of the oil suction hose.
- Wash the pickup body in white spirit and, if possible, blow out with compressed air.
- Always replace a damaged pickup body.
- Flush out the oil tank.

- Pull the pickup body (1) off the suction hose (2).

Reassemble in the reverse sequence.

Pickup body

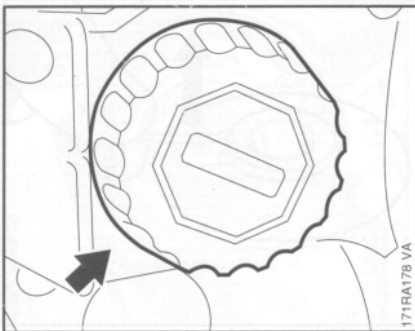

- Unscrew oil filler cap and drain the oil tank.

Note: Collect chain oil in a clean container or dispose of properly.

Assembly is a reversal of the disassembly sequence.

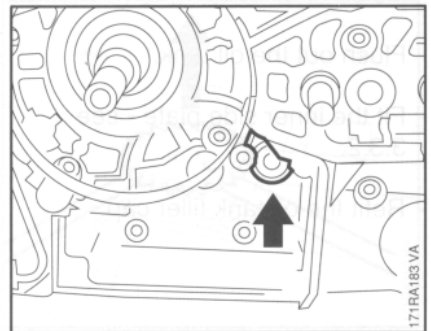

Suction hose

- Remove the oil pump - see 9.4.1.
- Use pliers to grip the tab of the oil hose and pull it out of the bore.

- Insert suction hose in bore.
- Use a blunt tool to push the end of the suction hose into the crankcase so that the tab locates it its seat at the bottom right.
- This operation is easier if the bead of the hose is lubricated with a little oil.

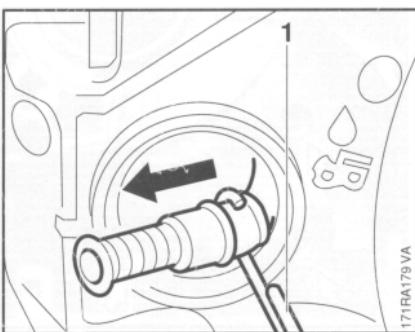

- Use assembly hook (1) 5910 893 8800 to pull the pickup body out of the oil tank.

Note: Avoid stretching the oil hose.

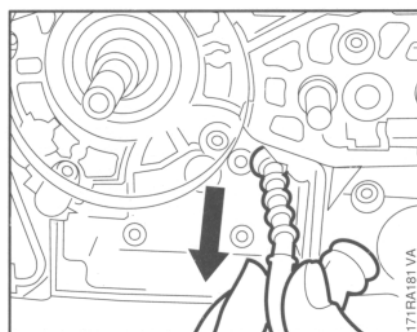

- Pull suction hose and pickup body out of the crankcase.

9.2 Valve

A valve is installed in the tank wall to keep internal tank pressure equal to atmospheric pressure.

Cleaning the valve

- Unscrew the oil filler cap.
- Drain the oil tank.

Note: Collect chain oil in a clean container or dispose of it properly at an approved disposal site.

- Remove the inner side plate - see 3.3.1.
- Blow valve clear with compressed air - from outside to inside of tank.
- Flush out the oil tank.
- Fit the inner side plate - see 3.3.2.
- Refit the oil tank filler cap.

Replacing the valve

- Unscrew the oil filler cap.
- Remove the inner side plate - see 3.3.1.

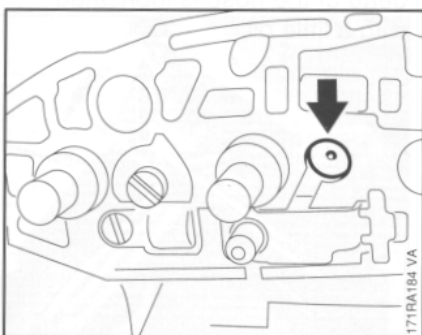

- Apply a drift from outside and carefully drive the vent valve out of the crankcase and remove it from the oil tank.

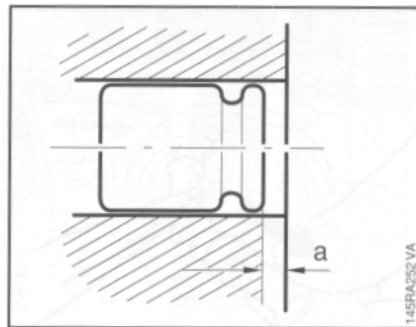

- Use a 7 mm (9/32") drift to carefully press in the new valve until it is about 1.0 mm (3/64") below the face of the crankcase.
- Refit the inner side plate - see 3.3.2.
- Fit the oil filler cap.

9.3 Spur Gear

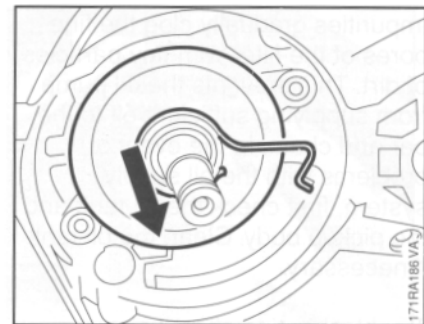

- Remove the clutch - see 3.2.
- Pull the worm with drive spring out of the oil pump and off the crankshaft stub.

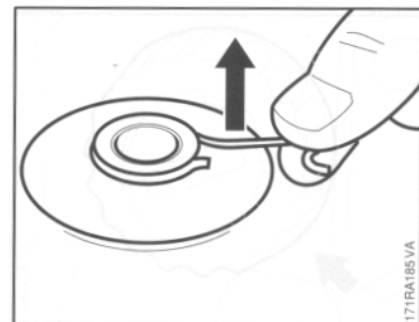

- If necessary, remove the drive spring from the worm.

Reassemble in the reverse sequence.

9.4 Oil Pump
9.4.1 Removing and Installing

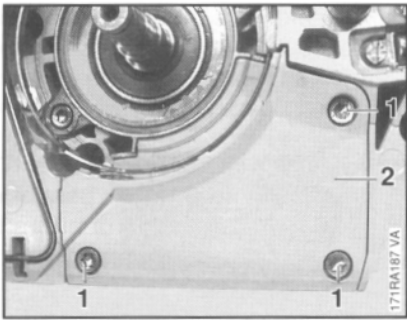

- Remove the spur gear - see 9.3.
- Take out the screws (1).
- Remove the cover (2).

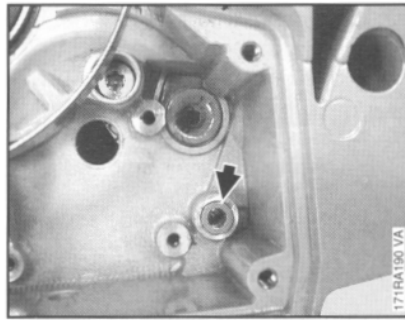

- Take the sealing ring out of the crankcase bore.

Reassemble in the reverse sequence.

9.4.2 Servicing

Always check the suction hose and pickup body before disassembling the oil pump.

- Remove the oil pump - see 9.4.1.

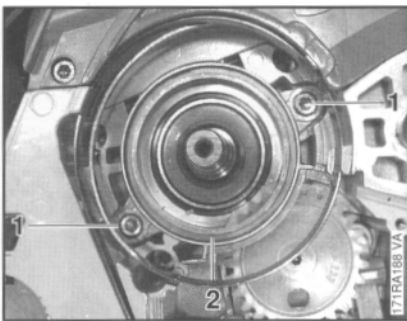

- Take out the screws (1).
- Remove the cover (2).

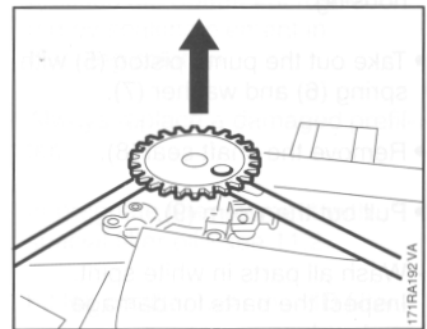

- Ease the spur gear off the pump.

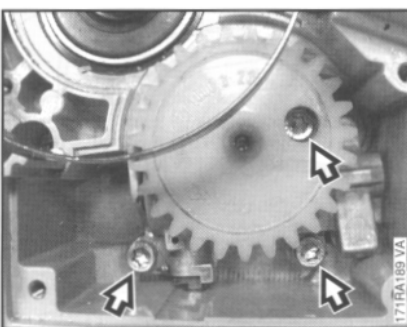

- Take out the screws.
- Pull out the oil pump.

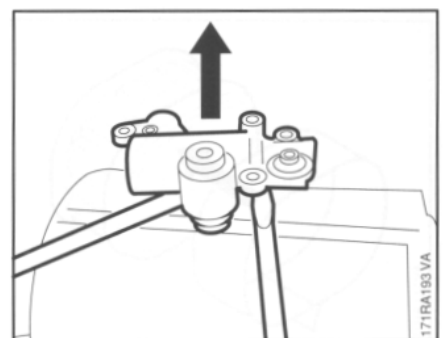

- Pry away the oil pump.

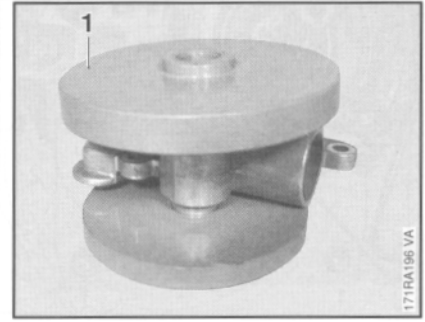
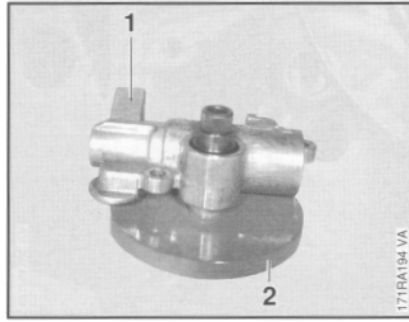
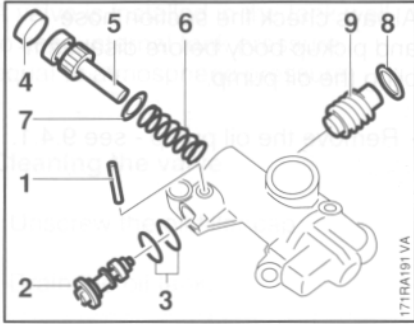

- Use a 2 mm (5/64") drift to drive out the spring pin (1).
- Pull out the control bolt (2).
- Remove the O-rings (3).
- Pry the plug (4) out of the housing.
- Take out the pump piston (5) with spring (6) and washer (7).
- Remove the shaft seal (8).
- Pull out the worm (9).
- Wash all parts in white spirit. Inspect the parts for damage and replace as necessary.

- Place pump housing (1) on base (2) 1124 893 5200.
- Clean sealing face with a standard commercial, solvent-based degreasant containing no chlorinated or halogenated hydrocarbons - see 11.2.
- Lubricate lips of shaft seal with grease - see 11.2.
- Apply thin coating of sealant, see 11.2, to circumference of shaft seal.
- Slip the shaft seal, open side facing the pump housing, over the worm.

- Use press plate (1) 1124 893 5100 to install spur gear.

Reassemble in the reverse sequence.

- Always install new O-rings.
- Coat pump piston and worm with grease, see 11.2, before installing.

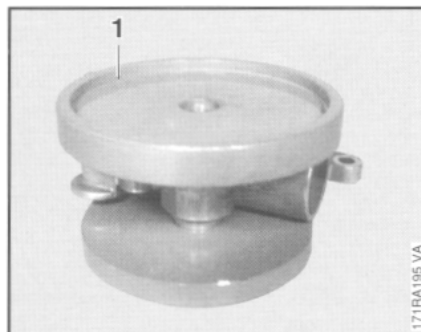

- Press home with press plate (1) 1124 893 5100.

10. FUEL SYSTEM

10.1 Air Filter

Dirty and clogged air filters reduce engine power, increase fuel consumption and make starting more difficult.

The air filter should always be cleaned when engine power begins to drop off.

- Wash the filter in a fresh, non-flammable cleaning solution (e.g. warm soapy water) and, if possible, blow out with compressed air. Soften encrusted dirt by soaking the filter in cleaning solution.
- Always replace a damaged air filter.

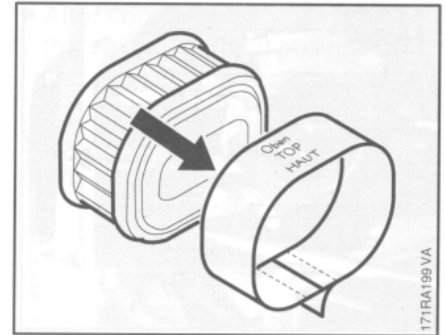

HD filter (special accessory)

- Pull off the felt prefilter.
- Wash prefilter mesh in a fresh, non-flammable cleaning solution (e.g. warm soapy water) and, if possible, blow out with compressed air. Soften encrusted dirt by soaking element in cleaning solution.
- Always replace a damaged prefilter.
- Impregnate filter element with special filter oil - see 11.2.
- Fit felt prefilter over the HD filter.

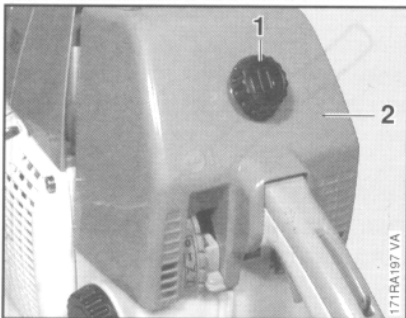

- Unscrew the twist lock (1).
- Remove the carburetor box cover (2).

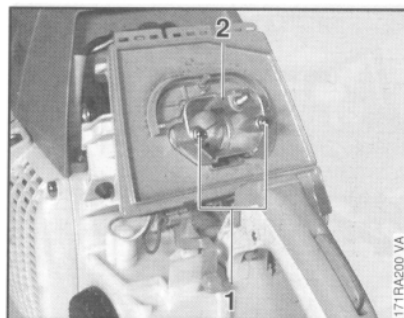

- Unscrew the collar nuts (1).
- Pull off the flange (2).

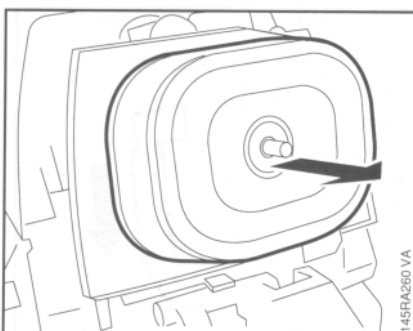

- Remove the air filter.

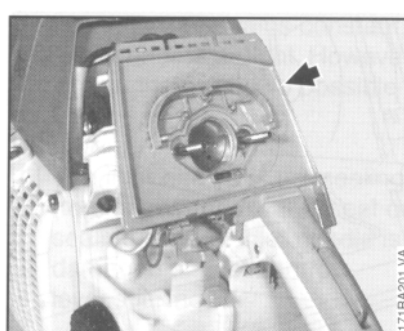

- Remove the filter base.

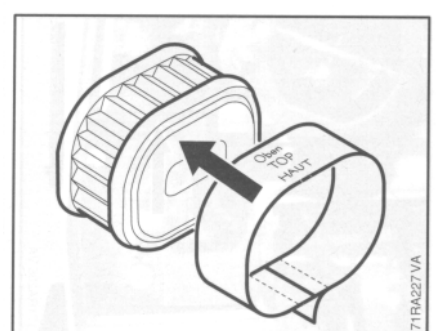

- The word "TOP" must face up.

Reassemble in the reverse sequence.

10.2 Carburetor
10.2.1 Removing and Installing

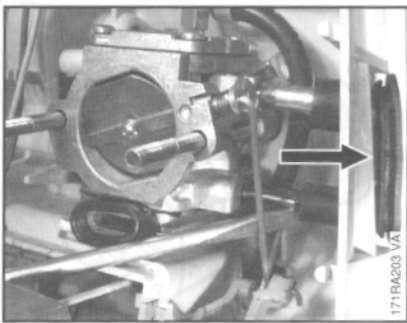

- Remove the filter base - see 10.1.
- Pull the grommet off the adjusting screws and out of the housing.

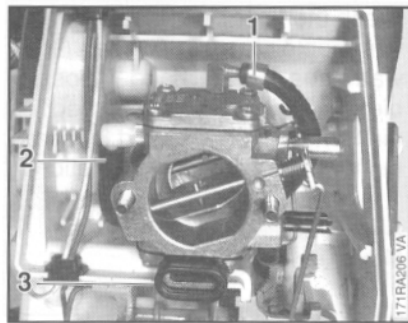

- Disconnect the impulse hose (1) and fuel hose (2).
- Pull off the sleeve (3).

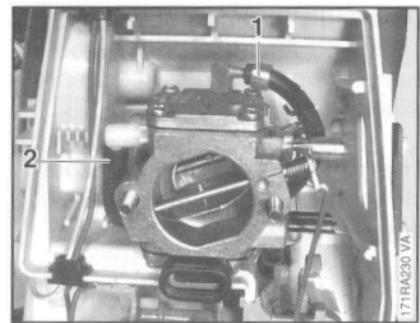

- After pushing carburetor into position, check that elbow connectors are properly seated in impulse hose (1) and fuel hose (2).

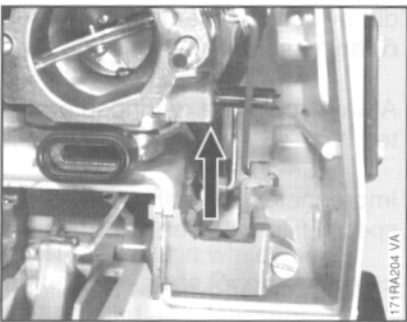

- Remove the handle molding - see 8.2.
- Disconnect the throttle rod from the double lever.



- Lift away the carburetor.

Reassemble in the reverse sequence.

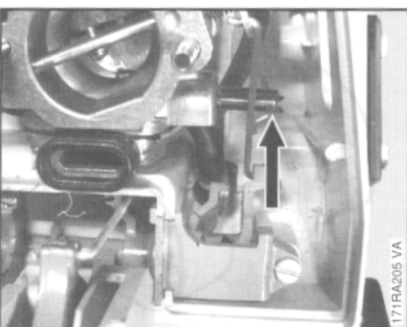

- Disconnect choke rod from the choke lever.

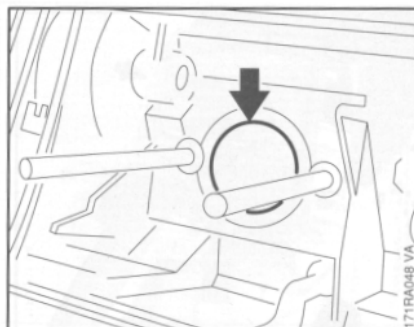

- Before installing the carburetor, check that sleeve is in position.

10.2.2 Leakage Test

The carburetor can be tested for leaks with the carburetor and crankcase tester 1106 850 2905.

- Remove filter base - see 10.1.

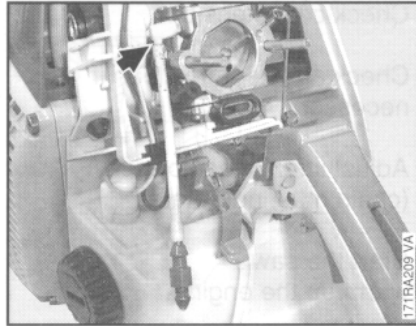

- After completing the test, open the vent screw and pull the fuel line off the elbow connector.
- Install the filter base - see 10.1.

- Push the fuel line with nipple onto the carburetor's elbow connector.

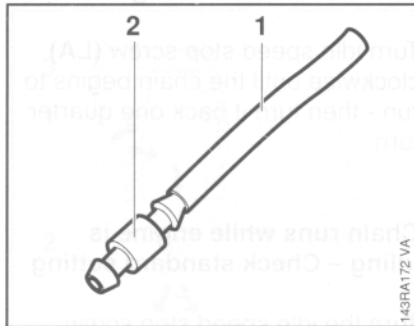

- Push the fuel line (1) 1110 141 8600 onto the nipple (2) 0000 855 9200.

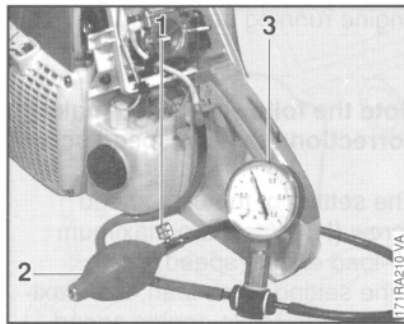

- Push the nipple into the tester's pressure hose.
- Close the vent screw (1) on the rubber bulb (2) and pump air into the carburetor until the pressure gauge (3) shows a reading of approx. 0.4 bar (5.8 psi).

If this pressure remains constant, the carburetor is airtight. However, if it drops, there are two possible causes:

1. The inlet needle is not sealing (foreign matter in valve seat or sealing cone of inlet needle is damaged or inlet control lever sticking).
2. The metering diaphragm is damaged.

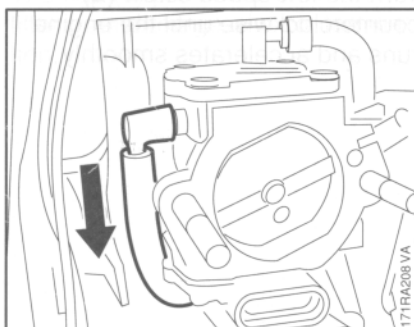

- Pull off the fuel hose.

In either of these cases the carburetor must be removed and serviced.

10.2.3 Adjustment

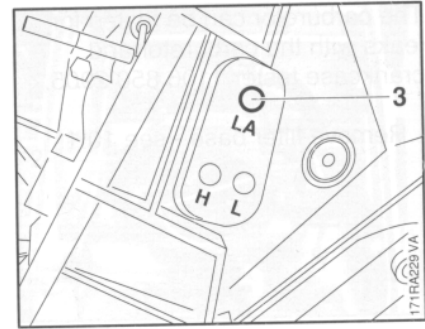
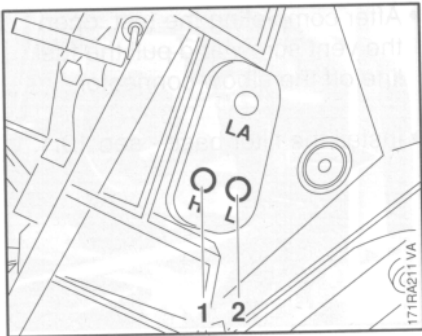

Standard setting

If the carburetor has to be adjusted from scratch, first carry out the standard setting.

- Carefully screw down both adjusting screws until they are hard against their seats.

Then make the following adjustments:

H = Open high speed screw (1) 1 full turn

L = Open low speed screw (2) 1 full turn

A slight correction **may** be necessary if the saw is used at high altitudes (mountains) or at sea level.

For corrections to high speed screw (**H**):

Use a tachometer - do not exceed max. permissible engine speed.

Engine can be damaged by lack of lubricant and overheating.

Maximum engine speed with bar and properly tensioned chain: 12,000 rpm

Note: If no tachometer is available, do not turn the high speed or low speed screws beyond the standard setting to make the mixture leaner.

- Check chain tension.
- Check air filter and clean if necessary.
- Adjust idle speed correctly (chain must not rotate).
- Start the saw - warm up the engine.

Turn high speed screw (**H**) and low speed screw (**L**) clockwise for leaner mixture at high altitudes or counterclockwise for richer mixture at sea level.

Turn screws very slowly and carefully - even slight adjustments produce a noticeable change in engine running behavior.

Note the following when making corrections to high speed screw:

The setting of the high speed screw (**H**) affects the maximum off-load engine speed. If the setting is too lean, the maximum permissible engine speed will be exceeded and increase the risk of engine damage.

Adjusting idle speed

A correction at the low speed screw (**L**) usually necessitates a change in the setting of the idle speed screw (**LA**).

Engine stops while idling – Check standard setting

Turn idle speed stop screw (**LA**) clockwise until the chain begins to run - then turn it back one quarter turn.

Chain runs while engine is idling - Check standard setting

Turn the idle speed stop screw (**LA**) counterclockwise until the chain stops running - and then turn it about another quarter turn in the same direction.

Erratic idling behavior, poor acceleration

Idle setting too lean. Turn the low speed screw (**L**) counterclockwise until the engine runs and accelerates smoothly.

10.3 Tank Vent

Correct operation of the carburetor is only possible if atmospheric pressure and internal fuel tank pressure are equal at all times. This is ensured by the tank vent.

Important: In the event of trouble with the carburetor or the fuel supply system, always check and clean the tank vent.

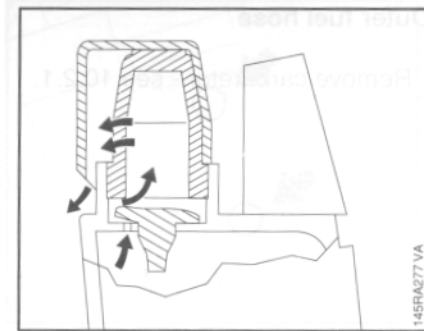

Equalization of pressure from the inside outwards takes place via the bore in the tank, the valve and sintered filter.

- Remove the carburetor box cover - see 10.1.

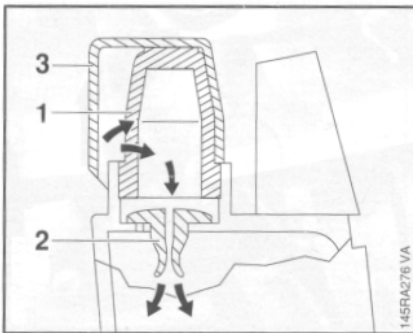

Equalization of pressure from the outside inwards takes place via the sintered filter (1) and the valve (2).

Note: The sintered filter helps prevent dirt entering the valve or the tank. The cap (3) protects the sintered filter from damage and contamination.

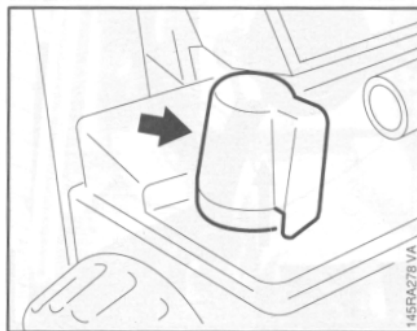

- Pull off the cap.

10.4 Pickup Body

The diaphragm pump draws fuel out of the tank and into the carburetor via the fuel hose. Any impurities mixed with the fuel are retained by the pickup body (filter). The fine pores of the filter eventually become clogged with minute particles of dirt. This restricts the passage of fuel and results in fuel starvation.

Important: In the event of trouble with the fuel supply system, always check the fuel tank and the pickup body first. Clean the fuel tank if necessary.

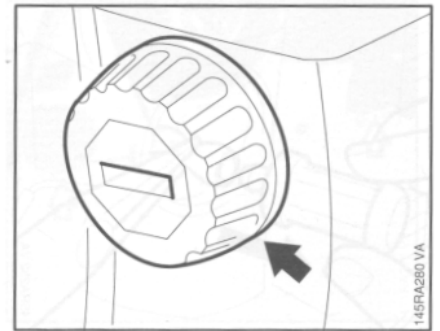

Cleaning the fuel tank

- Unscrew the filler cap and drain the tank.
- Pour a small amount of clean gasoline into the tank.
- Close the tank and shake the saw vigorously.
- Open the tank again and drain it.

Note: Dispose of old fuel at approved disposal site.

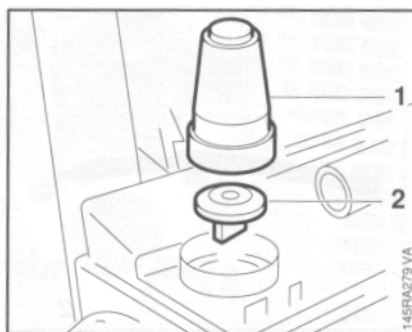

- Pull the sintered filter (1) and valve (2) out of the tank.

10.5 Fuel Hoses

Outer fuel hose

- Remove carburetor - see 10.2.1.

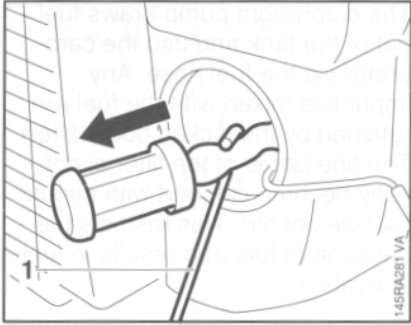

Pickup body

- Use the assembly hook (1) 5910 893 8800 to pull the pickup body out of the fuel tank.

Note: Do not stretch the fuel hose while removing it.

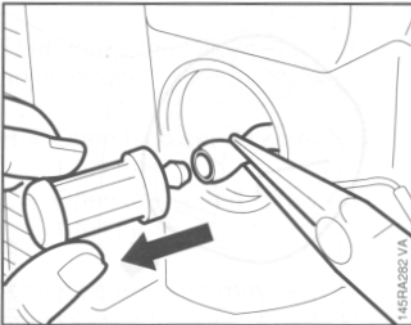

- Pull the pickup body off the fuel hose.
- Fit a new pickup body.

Reassemble in the reverse sequence.

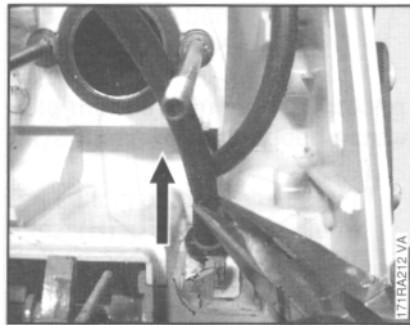

- Pull out the fuel hose.

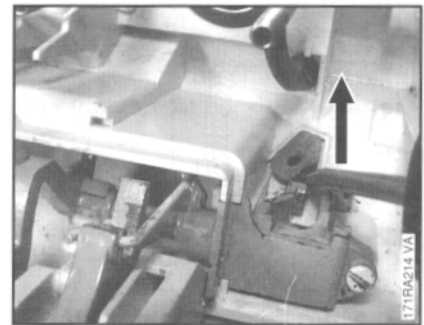

- Pry the flange of the fuel hose out of the fuel tank.

- Pull out the fuel hose.

Reassemble in the reverse sequence.

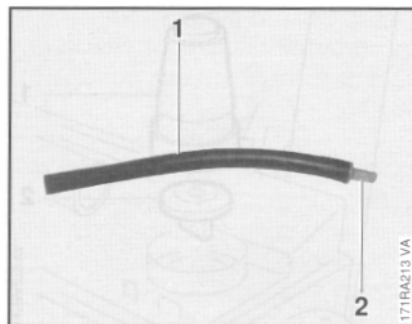

- Pull fuel hose (1) off the connector (2).



- Coat the flange of the fuel hose with a little oil.

- Straight side (1) of flange must locate against tank housing.

10.6 Tank Housing

- Drain the tank housing.

Note: Collect fuel in a clean container or dispose of it at an approved disposal site.

- Remove carburetor - see 10.2.1.

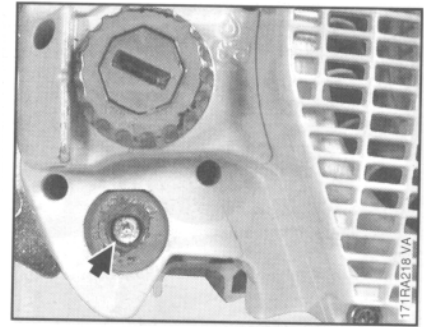
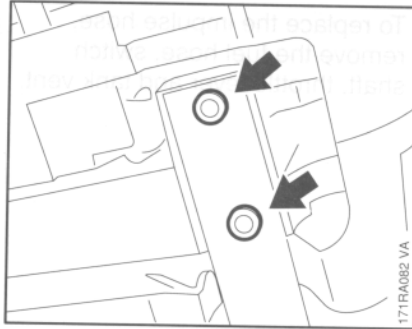

- Take out the front handle mounting screws on the underside of the machine.
- Remove the front handle.
- Remove the short circuit and ground wires - see 5.4.

- Take the screw out of the buffer.

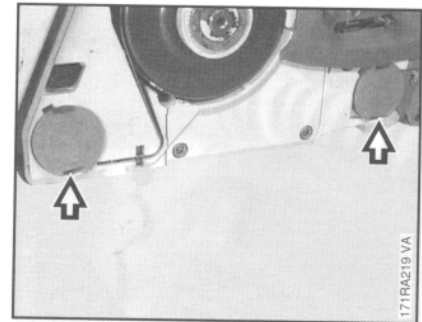
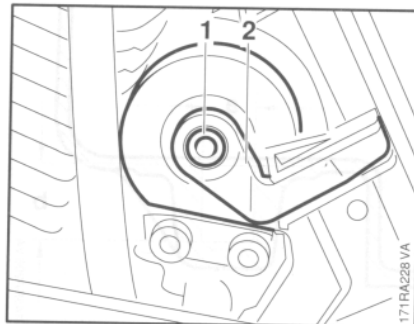
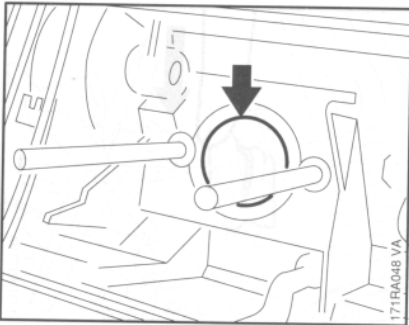

- Take the sleeve out of the manifold.

- Unscrew the center screw (1).
- Remove the support (2).

- Pry the plugs out of the annular buffers at the clutch side.

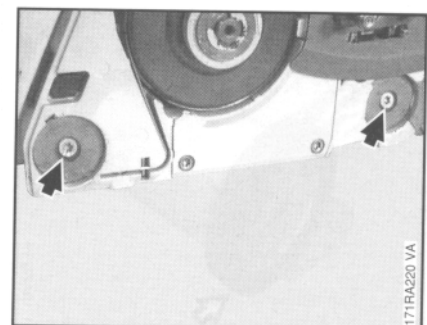
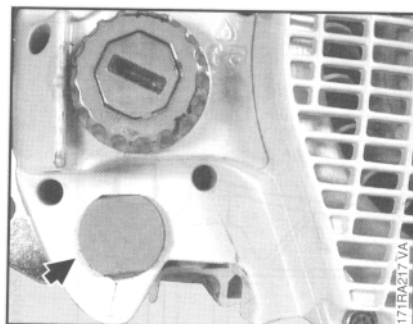
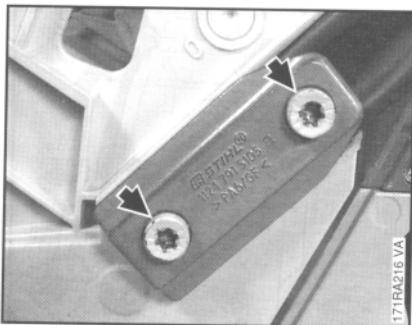

Important: Heat the screwed joints. Do not overheat polymer.

- Remove the mounting screws from the side of the front handle.

- Pry the plug out of the annular buffer at the starter side.

- Take out the annular buffer mounting screws.

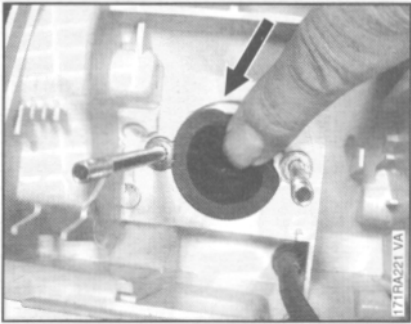

- Pull the tank housing forward and push the manifold flange out of the tank housing at the same time.

- To replace the impulse hose, remove the fuel hose, switch shaft, throttle lever and tank vent.

- An M6x18 pan head screw must then be used in place of the original special self-threading screw.

Reassemble in the reverse sequence.

Note: If a screw thread is stripped in one of the mounting holes for special self-threading screws, the tank housing can be repaired by installing a thread insert.

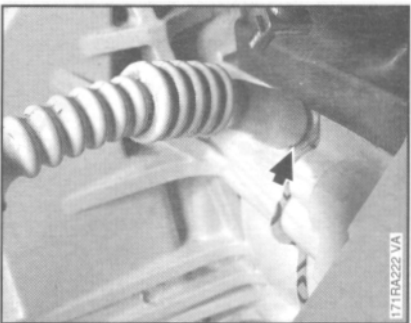

- Pull the impulse hose off the nipple.

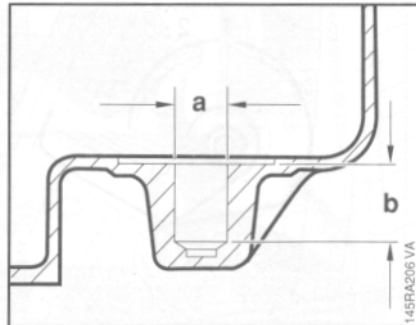

- The stripped thread must be drilled out to a diameter of 'a' = 8.5 mm and a depth of 'b' = 15 mm (approx. 9/16").

Caution: Do not exceed the specified hole depth of 15 mm.

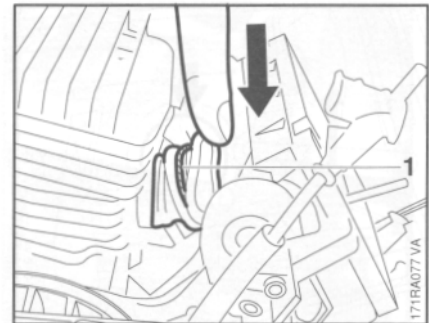

- Fit the manifold in the tank housing intake opening as follows: Wind a piece of string (1) (approx. 15 cm / 6" long) around the back of the manifold flange. Pass the ends of the string through the intake opening.

- Push the manifold down.

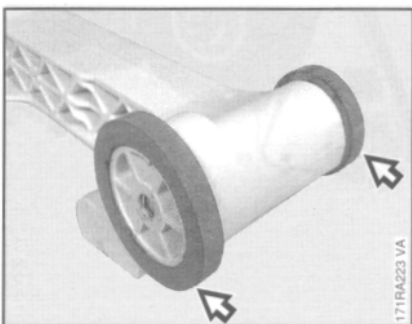

- Remove the rings from the tank housing.

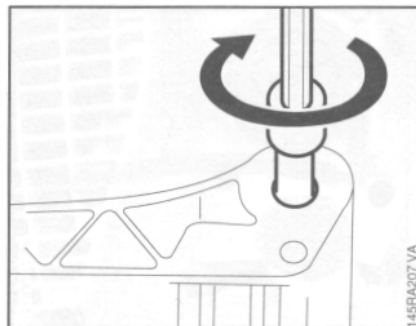

- Fit an M6x10 screw with washer in the thread insert.
- Screw the thread insert into the tank housing.

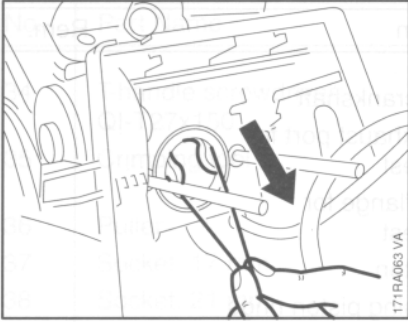

- Pull the ends of the string outward.

Note: The manifold flange is thus pulled through the tank housing intake opening without damaging the manifold.

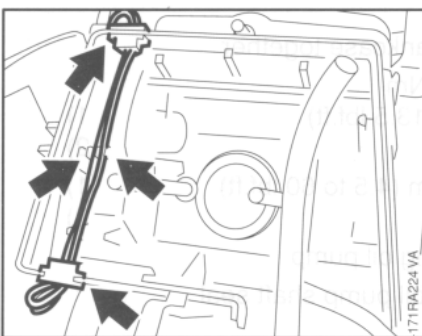

- All wires must be properly located in their retainers.
- Coat threads of front handle mounting screws with Loctite, see 11.2, and torque down to 8.0 Nm (5.9 lbf.ft).

11. Special Servicing Tools and Aids
11.1 Special Servicing Tools

No	Part Name	Part No.	Application	Rem.
1	Locking strip for piston	0000 893 5903	Blocking crankshaft	
2	Flange	1124 850 4205	Sealing exhaust port for leakage test	
3	Clamp	0000 890 4400	Securing flange for leakage test	
4	Wooden assembly block	1108 893 4800	Fitting piston	
5	Clamping strap	0000 893 2600	Compressing piston rings	
6	Test flange	1106 850 4201	For leakage test	
7	- Sleeves	1127 851 8300		
8	Carburetor and crankcase tester	1106 850 2905	Testing carburetor and crankcase for leaks	
9	Vacuum pump	0000 850 3501	Testing crankcase for leaks	
10	- Nipple	0000 855 9200		
11	- Fuel line	1110 141 8600		
12	- Plug	1122 025 2200		
13	Puller	5910 890 4400	Removing oil seals	
14	- Jaws (No. 3.1)	0000 893 3706		
15	Press sleeve	1127 893 2400	Installing oil seal (starter side/clutch side)	
16	Assembly sleeve	1124 893 4600	Protecting oil seal at clutch side	
17	Assembly drift	1111 893 4700	Fitting piston pin	
18	Installing tool 12	5910 890 2212	Fitting hookless snap rings in piston	
19	Stud puller M8	5910 893 0506	Removing bar mounting studs	
20	Setting gauge	1111 890 6400	Setting air gap between ignition module and flywheel	
21	Assembly hook	5910 893 8800	Removing pickup bodies	
22	Assembly stand	5910 890 3100	Holding saw for repairs	
23	- Clamping bar		5910 890 2005	
24	Assembly tube	1117 890 0900	Attaching the brake spring	
25	Service tool AS	5910 007 2205	Removing crankshaft (clutch side)	
26	- Screw sleeve	5910 893 2421	Installing crankshaft	
27	Service tool ZS	5910 007 2220	Removing crankshaft (starter side)	
28	- Screws	9022 341 1190		
29	- Screw sleeve	5910 893 2408	Pulling crankcase together	
30	Torque wrench	5910 890 0301	0.5 to 18 Nm (0.325 to 13.5 lbf.ft)	1)
		5910 890 0302		2)
31	Torque wrench	5910 890 0311	6 to 80 Nm (4.5 to 60 lbf.ft)	1)
		5910 890 0312		2)
32	Base	1124 893 5200	Assembling oil pump	
33	Press plate	1124 893 5100	Installing oil pump shaft seal	

No	Part Name	Part No.	Application	Rem.
34	T-handle screwdriver QI-T27x150	5910 890 2400	For all IS screws	3)
35	Crimping tool	5910 890 8210	Attaching connectors to electrical wires	
36	Puller	1106 893 4501	Removing flywheel	
37	Socket, 17 mm	5910 893 5610	Flywheel nut	
38	Socket, 21 mm	5910 893 5615	Clutch	
39	Screwdriver bit T27x125	0812 542 2104	IS screws	
40	Press arbor	1124 893 7200	Removing and installing ball bearing (clutch side)	
41	Press arbor	1119 893 2401	Removing and installing ball bearing (starter side)	

Remarks:

- 1) Always use torque wrench to tighten 'P' screws.
- 2) Wrench has optical/acoustic signal.
- 3) On 'P' screws, use for releasing only.

11.2 Servicing Aids

No.	Part Name	Part No.	Application
1	Lubricating grease	0781 120 1111	Oil seals, oil pump drive. chain sprocket bearing
2	Standard commercial, solvent-based degreasant without chlorinated or halogenated hydrocarbons		Cleaning crankshaft stub
3	STIHL special lubricant	0781 417 1315	Bearing bore in rope rotor, rewind spring in starter cover
4	Ignition lead HTR (10 m/33")	0000 930 2251	
5	Electrician's repair kit	0000 007 1013	
6	Graphite grease		Peg on starter pawl
7	Dirko sealant (100 g/3.5 oz)	0783 830 2120	Outside diameter of oil seals
8	STIHL multipurpose grease	0781 120 1109	High voltage output on ignition module
9	Medium-strength threadlocking (Loctite 242)	0786 111 1101	Securing screws, see 2.6
10	High-strength threadlocking (Loctite 648)	0786 110 0126	Securing screws, see 2.6