



SERVICE MANUAL

Number 14

**Sterndrive Units
Alpha One
Generation II**

MerCruiser #14 Sterndrive Units

90-818177-3

MerCruiser #14 Sterndrive Units

90-818177-3

IMPORTANT INFORMATION

Section 1A - General Information

**1
A**

Table of Contents

How To Use This Manual	1A-2	Decal Application	1A-5
Page Numbering	1A-2	Decal Removal	1A-5
Introduction	1A-3	Instructions for "Wet" Application ...	1A-5
Special Product Information	1A-3	Painting Procedures	1A-7
Directional References	1A-3	Cleaning & Painting Aluminum	
Propeller Rotation	1A-4	Propellers & Gear Housings	1A-7
Serial Number Locations and			
Engine Designation Decal	1A-4		
Sterndrive Unit Serial Number			
Location	1A-5		

How To Use This Manual

This Manual is divided into sections which represent major components and systems. Some sections are further divided into parts which more fully describe the component. Sections and parts are listed at the front of this manual.

Page Numbering

Two number groups appear at the bottom of each page. Following is an example and description.

Page 1A-2

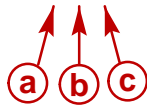

90-17431--4 FEBRUARY 1998

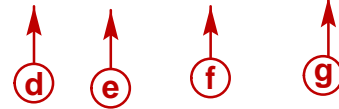

- a**- Section Number
- b**- Section Part
- c**- Page Number
- d**- Manual Part Number
- e**- Revision Number
- f**- Month Printed
- g**- Year Printed

Introduction

This comprehensive overhaul and repair manual is designed as a service guide for the Mercury MerCruiser models previously listed. It provides specific information, including procedures for disassembly, inspection, assembly and adjustment, to enable dealers and service mechanics to repair these products.

Before attempting repairs, it is suggested that the procedure be read to gain knowledge of the methods and tools used and the cautions and warnings required for safety.

Special Product Information

During production of these models, special product improvements and changes have been made to increase product reliability and performance. Such changes to a sterndrive assembly component(s) are covered in the "Special Information" portion of the appropriate sterndrive assembly section. (Refer to the section "Index".) Serial number breaks are provided, where applicable, for ease of identification.

Directional References

Front of boat is bow; rear is stern. Starboard side is right side; port side is left side. In this service manual, all directional references are given as they appear when viewing boat from stern, looking toward bow.

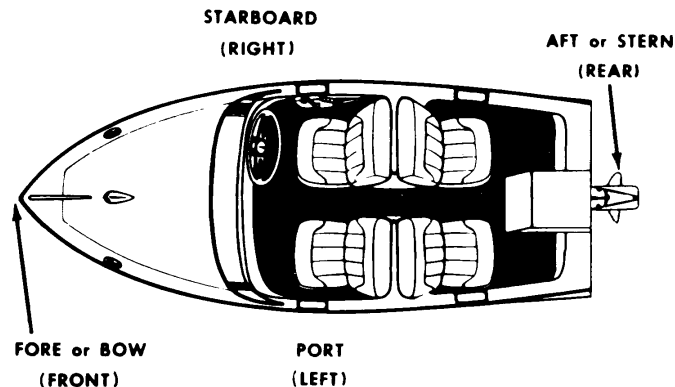

Propeller Rotation

Propeller rotation for sterndrive can be right hand or left hand rotation as viewed from the aft end of the propeller.

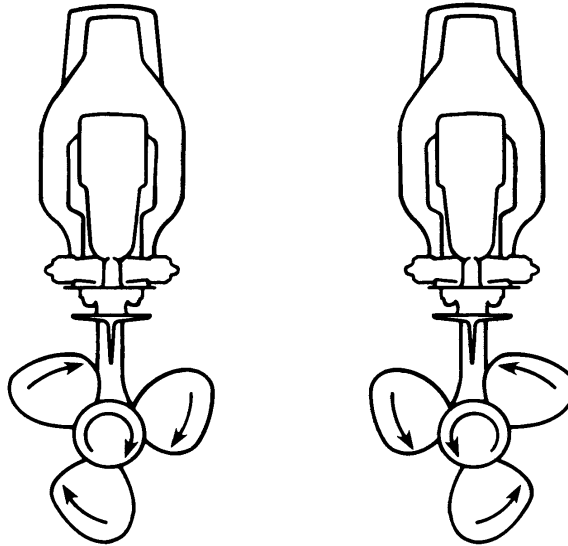

Right Hand Rotation

Left Hand Rotation

Serial Number Locations and Engine Designation Decal

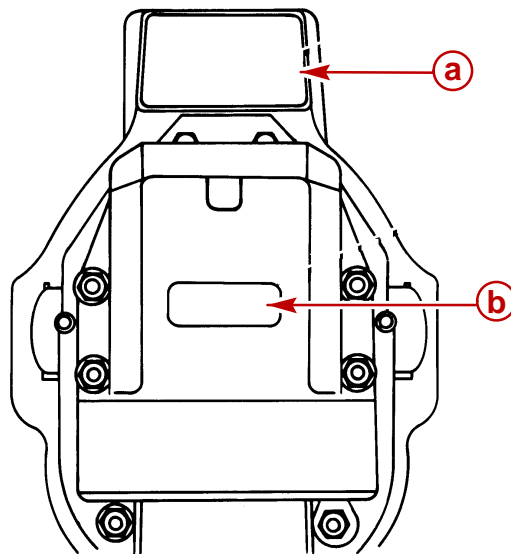

- a** - Transom Assembly Serial Number
- b** - Engine Designation Decal

22031

Sterndrive Unit Serial Number Location

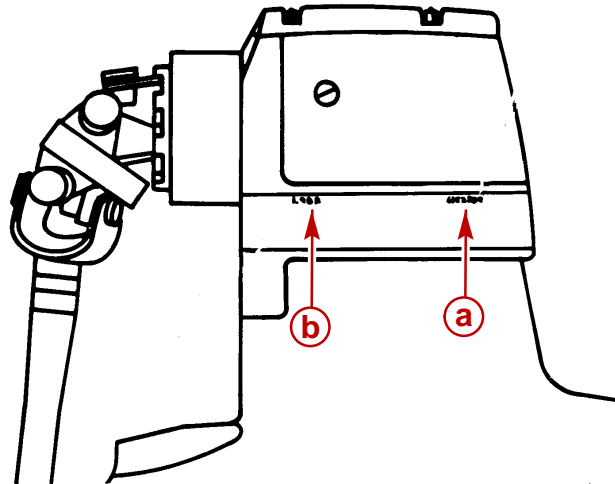

22026

Sterndrive Unit Serial Number Location - Port Decal (Also Located Under Decal On Housing)

- a** - Sterndrive Unit Serial Number
- b** - Sterndrive Unit Gear Ratio

Decal Application

Decal Removal

1. Mark decal location before removal to assure proper alignment of new decal.
2. Carefully soften decal and decal adhesive with a heat gun or heat blower while removing old decal.
3. Clean decal contact area with a 1:1 mixture of isopropyl alcohol and water.
4. Thoroughly dry decal contact area and check for a completely cleaned surface.

Instructions for “Wet” Application

NOTE: The following decal installation instructions are provided for a “Wet” installation. **All** decals should be applied wet.

TOOLS REQUIRED

1. Plastic Squeegee*
2. Stick Pin
3. Dish Washing **Liquid/Detergent without ammonia**** “Joy” and “Drift” are compatible for this process.

* Automotive Body Filler Squeegee

** Do not use a soap that contains petroleum based solvents.

SERVICE TIP: Placement of decals using the “Wet” application will allow time to position decal. Read entire installation instructions on this technique before proceeding.

TEMPERATURE

IMPORTANT: Installation of vinyl decals should not be attempted while in direct sunlight. Air and surface temperature should be between 60°F (15°C) and 100°F (38°C) for best application.

SURFACE PREPARATION

IMPORTANT: Do not use a soap or any petroleum based solvents to clean application surface.

Clean entire application surface with mild dish washing liquid and water. Rinse surface thoroughly with clean water.

DECAL APPLICATION

1. Mix $\frac{1}{2}$ ounce (16 ml) of dish washing liquid in one gallon (4 l) of cool water to use as wetting solution.

NOTE: Leave protective masking, if present, on the face of decal until final steps of decal installation. This will ensure that the vinyl decal keeps its shape during installation.

2. Place the decal face down on a clean work surface and remove the paper backing from “adhesive side” of decal.
3. Using a spray bottle, flood the entire “adhesive side” of the decal with the pre-mixed wetting solution.
4. Flood area where the decal will be positioned with wetting solution.
5. Position pre-wetted decal on wetted surface and slide into position.
6. Starting at the center of the decal, “lightly” squeegee out the air bubbles and wetting solution with overlapping strokes to the outer edge of the decal. Continue going over the decal surface until all wrinkles are gone and adhesive bonds to the cowl surface.
7. Wipe decal surface with soft paper towel or cloth.
8. **Wait 10 - 15 minutes.**
9. Starting at one corner, “carefully and slowly” pull the masking off the decal surface at a 180° angle.

NOTE: To remove any remaining bubbles, pierce the decal at one end of the bubble with stick pin and press out the entrapped air or wetting solution with your thumb (moving toward the puncture).

Painting Procedures

Cleaning & Painting Aluminum Propellers & Gear Housings

WARNING

Avoid serious injury from flying debris. Avoid serious injury from airborne particles. Use eye and breathing protection with proper ventilation.

PROPELLERS

1. Sand the entire area to be painted with 3M 120 Regalite Polycut or coarse Scotch-Brite, disc or belts.
2. Feather edges of all broken paint edges. Try not to sand through the primer.
3. Clean the surface to be painted using PPG Industries DX330 Wax and Grease Remover or equivalent (Xylene or M.E.K.).
4. If bare metal has been exposed, use Quicksilver's Light Gray Primer.
5. Allow a minimum of 1 hour dry time and no more than 1 week before applying the finish coat.
6. Apply the finish coat using Quicksilver's EDP Propeller Black.

GEAR HOUSINGS

The following procedure should be used in refinishing gear housings. This procedure will provide the most durable paint system available in the field. The materials recommended are of high quality and approximate marine requirements. The following procedure will provide a repaint job that compares with a properly applied factory paint finish. It is recommended that the listed materials be purchased from a local Ditzler Automotive Finish Supply Outlet. The minimum package quantity of each material shown is sufficient to refinish several gear housings.

Procedure:

1. Wash gear housing with a muriatic acid base cleaner to remove any type of marine growth, and rinse with water, if necessary.
2. Wash gear housing with soap and water, then rinse.
3. Sand blistered area with 3M 180 grit sandpaper or P180 Gold Film Disc to remove paint blisters only. Feather edge all broken paint edges.
4. Clean gear housing thoroughly with (DX-330) wax and grease remover.
5. Spot repair surfaces where bare metal is exposed with (DX-503) alodine treatment.

IMPORTANT: Do not use any type of aerosol spray paints as the paint will not properly adhere to the surface nor will the coating be sufficiently thick to resist future paint blistering.

6. Mix epoxy chromate primer (DP-40) with equal part catalyst (DP-401) per manufacturers instructions, allowing proper induction period for permeation of the epoxy primer and catalyst.

IMPORTANT: Do not paint sacrificial zinc trim tab or zinc anode.

7. Cut out a cardboard "plug" for trim pump pocket to keep paint off of mating surface to maintain good continuity circuitry between trim tab and gear housing.

8. Allow a minimum of one hour drying time and no more than one week before top coating assemblies.
9. Use Ditzler Urethane DU9000 for Mercury Black and DU33414M for Sea Ray White. Catalyze the colors with Ditzler DU5 catalyst mixed 1:1 ratio. Reduce with solvents per Ditzler label.

⚠ CAUTION

Be sure to comply with instructions on the label for ventilation and respirators. Using a spray gun, apply one half to one mil even thickness. Let dry, flash off for five minutes and apply another even coat of one half to one mil film thickness. This urethane paint will dry to the touch in a matter of hours, but will remain sensitive to scratches and abrasions for a few days.

10. The type of spray gun used will determine the proper reduction ratio of the paint.

IMPORTANT INFORMATION

Section 1B - Maintenance

**1
B**

Table of Contents

Trim Pump Specifications	5A-2	Checking Lubricant for Water	1B-10
Valve Pressure Specifications	5A-2	Changing Lubricant	1B-12
Maintenance Schedules	1B-2	General Maintenance	1B-14
Maintenance Intervals	1B-2	Maintaining Power Package	
Gas Sterndrive	1B-2	Exterior Surfaces	1B-14
Routine Maintenance *	1B-2	Steering Head and Remote	
Scheduled Maintenance *	1B-3	Control Maintenance	1B-14
Quicksilver Maintenance Products	1B-4	Checking Quicksilver MerCathode	
Lubricating Shift Cable Pivot Points	1B-4	System	1B-14
Lubricating Propeller Shaft	1B-4	Maintaining Anodic Trim Tab or	
Lubricating Steering System	1B-5	Plate	1B-14
Power Steering Models	1B-5	Checking Optional Quicksilver	
Manual Steering Models	1B-5	Anti-Corrosion Anode Kit	1B-14
Lubricating Tie Bar Pivot Points	1B-6	Boat Bottom Care	1B-15
Models With Control Valve Mounted		Antifouling Paint	1B-15
On Starboard Transom Assembly ..	1B-6	Maintaining Ground Circuit	
Models With Control Valve Mounted		Continuity	1B-15
On Port Transom Assembly	1B-6	Power Package Layup (Out of	
Lubricating Transom and Gimbal		Season Storage)	1B-16
Assembly ,Hinge Pins and Gimbal Bearing	1B-7	Engine	1B-16
Checking and Adding Sterndrive Oil ...	1B-8	Sterndrive	1B-16
Models Without Drive Unit Gear		Power Package Recommissioning	1B-18
Lube Monitor	1B-8	Engine	1B-18
Models With Gear Lube Monitor	1B-9	Sterndrive	1B-18

Maintenance Schedules

Maintenance Intervals

Maintenance intervals and the tasks to be performed, as shown in this current schedule, or as found in a previously printed schedules, are generally based on an average boating application and environment. However, individual operating habits and personal maintenance preferences can have an impact on the suggested intervals. In consideration of these factors, Mercury MerCruiser has adjusted some maintenance intervals and corresponding tasks to be performed. In some cases, this may allow for more individual tasks to be performed in a single visit to the serving dealer, rather than multiple visits. Therefore, it is very important that the boat owner and servicing dealer discuss the current Maintenance Schedule and develop appropriate maintenance intervals to coincide with the individual operating habits, environment, and maintenance requirements.

⚠ CAUTION
Always disconnect battery cables from battery BEFORE working around electrical systems components to prevent injury to yourself and damage to electrical system should a wire be accidentally shorted.

Gas Sterndrive

Routine Maintenance *				
	Each Day Start	Each Day End	Weekly	Every Two Months
Check crankcase oil (interval can be extended based on experience).				
	•			
If operating in salt, brackish or polluted waters, flush cooling system after each use.				
		•		
Check drive unit oil level, trim pump oil level and power steering pump fluid level.				
			•	
Check water pickups for debris or marine growth. Check water strainer and clean. Check coolant level.				
			•	
Inspect drive unit anodes and replace if 50 percent eroded.				
			•	
Inspect fuel pump sight tube and have pump replaced if fuel is present.				
			•	
Check battery connections and fluid level.				
				•
Lubricate propeller shaft and the retorque nut (if operating in only freshwater, this maintenance may be extended to every four months).				
				•
Operating in Saltwater Only: treat engine surface with corrosion guard.				
				•

* Only perform maintenance which applies to your particular power package.

Gas Sterndrive (Continued)

Scheduled Maintenance *					
Annually	Every 100 Hours or Annually◆	Every 200 Hours or 3 Years◆	Every 300 Hours or 3 Years◆	Every 2 Years	Every 5 Years
Touch-up paint power package and spray with corrosion guard.					
•					
Change crankcase oil and filter.					
	•				
Change drive unit oil and retorque connection of gimbal ring to steering shaft.					
	•				
Replace fuel filter.					
	•				
Check steering system and remote control for loose, missing or damaged parts. Lubricate cables and linkages.					
	•				
Inspect U-joints, splines and bellows. Check clamps. Check engine alignment. Lubricate U-joint splines.					
	•				
Lubricate gimbal bearing and engine coupler.					
	• ⁸				
Check continuity circuit for loose or damaged connections. Test MerCathode® unit output on Bravo models.					
	•				
Retorque engine mounts.					
	•				
Check spark plugs, wires, distributor cap and ignition timing. Check and adjust idle speed.					
	•				
Clean flame arrestor and crankcase ventilation hoses. Replace PCV valve.					
	•				
Check electrical system for loose, damaged or corroded fasteners.					
	•				
Inspect condition and tension of belts.					
	•				
Check cooling system and exhaust system hose clamps for tightness. Inspect both systems for damage or leaks.					
	•				
Disassemble and inspect seawater pump and replace worn components.					
	•				
Clean seawater section of closed cooling system. Clean, inspect and test pressure cap.					
	•				
Replace coolant.					
				♠	•

* Only perform maintenance which applies to your particular power package.

◆ Whichever occurs first.

⁸ Lubricate engine coupler every 50 hours if operated at idle for prolonged periods of time.

♠ Interval will be reduced if not using extended life coolant.

Quicksilver Maintenance Products

We recommend the use of Quicksilver Maintenance Products where specified.

Lubricating Shift Cable Pivot Points

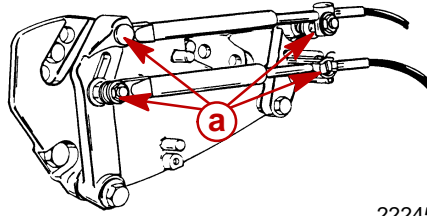

22245

a - SAE 20 Or 30 Engine Oil

Lubricating Propeller Shaft

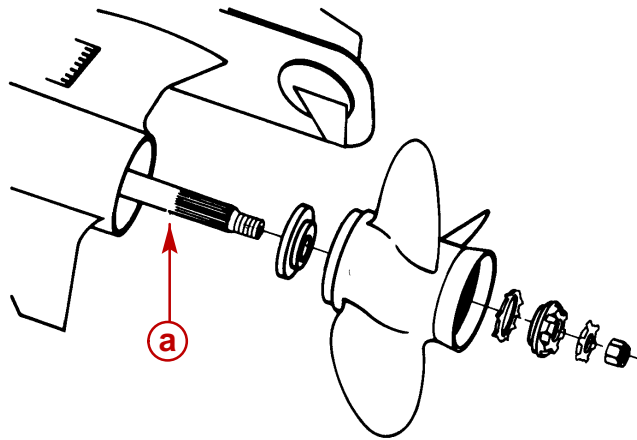

70134

a - Special Lubricant 101, 2-4-C Marine Lubricant With Teflon Or Perfect Seal With Teflon (Listed In Order Of Effectiveness)

Lubricating Steering System

⚠ WARNING

Transom end of steering cable **MUST BE** fully retracted into cable housing when lubricating cable. If cable is lubricated while extended, hydraulic lock of cable could occur.

Power Steering Models

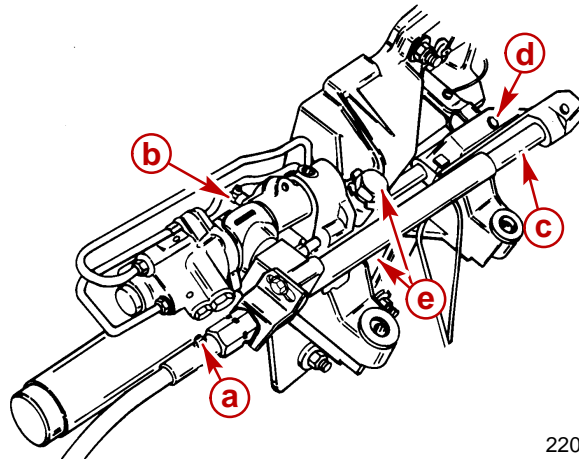

22023

Earlier Style Control Valve

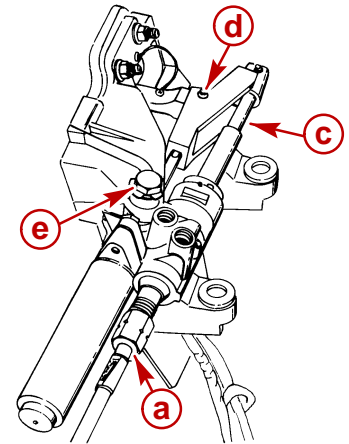

71901

Later Style Control Valve

- a** - Steering Cable Grease Fitting - 2-4-C Marine Lubricant With Teflon
- b** - Control Valve Grease Fitting - 2-4-C Marine Lubricant With Teflon
- c** - Steering Cable End - Special Lubricant 101
- d** - Pivot Point - Sae 20 Or 30 Engine Oil
- e** - Pivot Bolts - Special Lubricant 101

Manual Steering Models

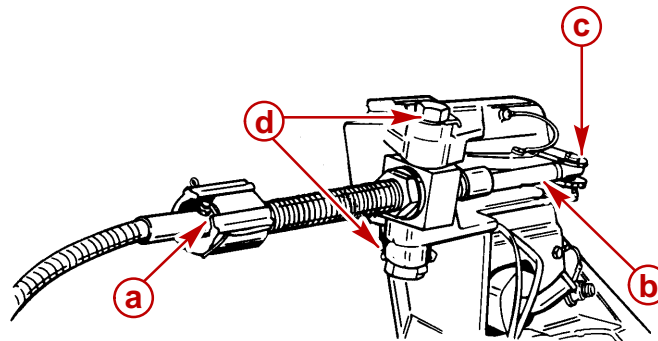

22055

- a** - Steering Cable Grease Fitting - 2-4-C Marine Lubricant With Teflon
- b** - Steering - Cable End And Exposed Portion - Special Lubricant 101
- c** - Pivot Points - SAE 20 Or 30 Engine Oil
- d** - Pivot Bolts - Special Lubricant 101

Lubricating Tie Bar Pivot Points

Models With Control Valve Mounted On Starboard Transom Assembly

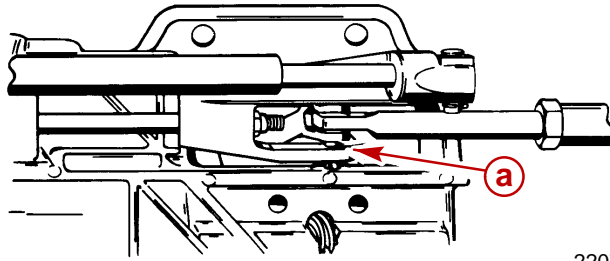

22079

Starboard Engine

a - SAE 20 Or 30 Engine Oil

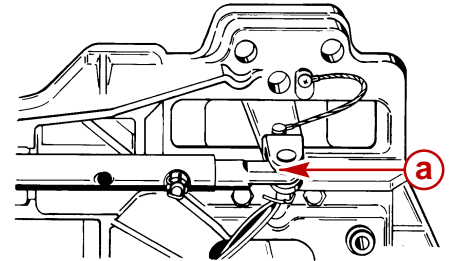

22079

Port Engine

Models With Control Valve Mounted On Port Transom Assembly

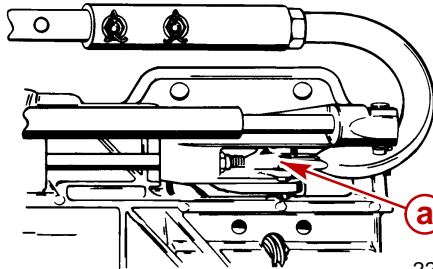

22079

Port Engine

a - SAE 20 Or 30 Engine Oil

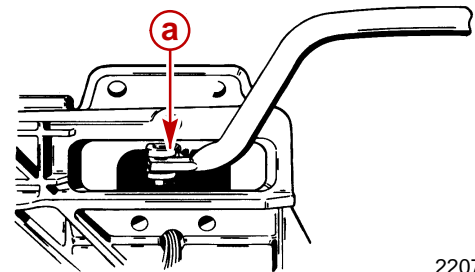

22079

Starboard Engine

Lubricating Transom and Gimbal Assembly ,Hinge Pins and Gimbal Bearing

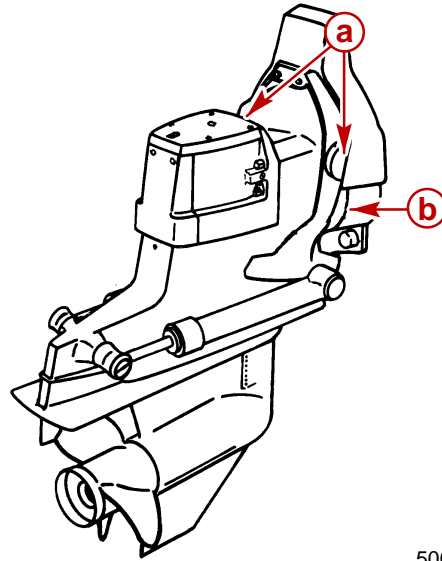

50072

- a** - Hinge Pins (One On Each Side)
- b** - Gimbal Bearing Grease Fitting - Quicksilver U-Joint And Gimbal Bearing Grease

Checking and Adding Sterndrive Oil

IMPORTANT: Position sterndrive unit in DOWN/IN position so that anti-ventilation plate is level.

Models Without Drive Unit Gear Lube Monitor

⚠ CAUTION

On models with Gear Lube Monitor, that have a dipstick in driveshaft housing cover: **DO NOT REMOVE DIPSTICK - DO NOT CHECK OIL LEVEL WITH DIPSTICK.** Removal of dipstick results in oil level raising/overflow condition, which can cause oil seal damage; if left open, drive unit will overflow.

1. Check oil level - oil should come up to line on dipstick. If oil is at proper level, reinstall oil dipstick and sealing washer. If oil is low, proceed to Step 2.

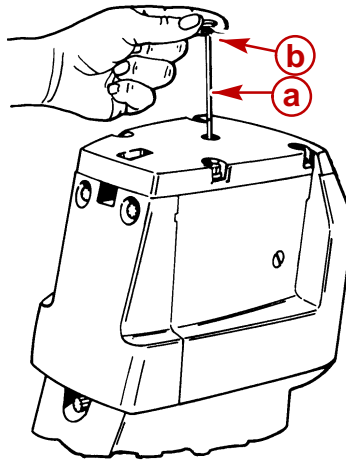

22098

- a - Oil Dipstick
- b - Sealing Washer (On Threads)

⚠ CAUTION

DO NOT attempt to fill drive unit through oil vent hole, as air will be trapped in drive unit and unit will be damaged from lack of lubrication.

⚠ CAUTION

If more than 2 fl. oz. (59 ml) of oil is required to fill drive unit, an oil leak may exist. Find and correct cause of leak before unit is placed in operation.

2. If oil level is low, reinstall dipstick; then, remove oil fill/drain plug and insert lubricant pump into oil fill/drain hole.

- Remove oil vent plug; then, fill drive unit (through oil fill/drain unit hole) with oil until an air-free stream of oil flows out of oil vent hole.

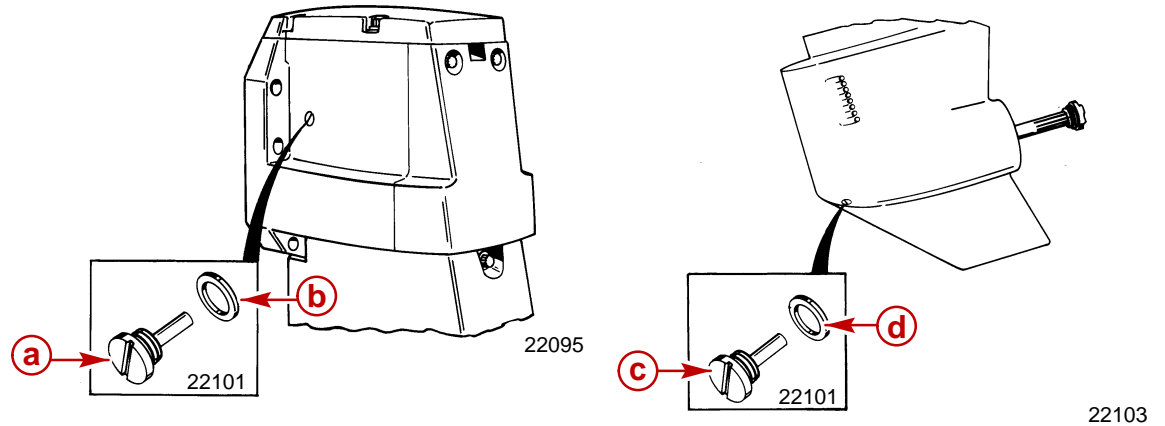

- a** - Oil Vent Plug
- b** - Sealing Washer Or O-ring
- c** - Oil Fill/Drain Plug
- d** - Sealing Washer Or O-ring

- Without removing lubricant pump from fill/drain hole, reinstall vent plug and sealing washer (or O-ring if equipped). Torque to 40 lb-in. (4 Nm).
- Remove lubricant pump and quickly reinstall fill/drain plug and sealing washer (or O-ring if equipped). Torque to 40 lb-in. (4 Nm).
- Recheck oil level, using dipstick.

Models With Gear Lube Monitor

IMPORTANT: Position drive unit in **DOWN/IN** position, verify that the anti-ventilation plate is level.

NOTE: Drive unit oil level is checked at gear lube monitor.



IMPORTANT: Oil level in gear lube monitor will rise and fall during drive operation; always check oil level when drive is cool and engine is shut down.

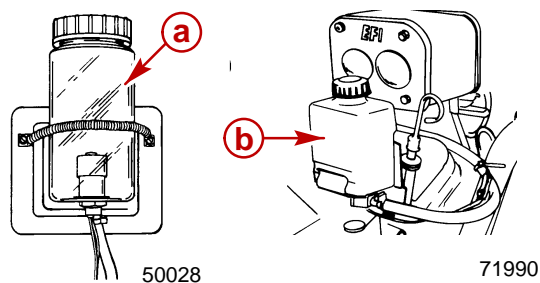

- a** - Round Gear Lube Monitor
- b** - Square Gear Lube Monitor

1. Fill gear lube monitor to "FULL" line on decal. Lubricate O-ring seal on gear lube monitor neck with sterndrive oil, to ensure ease of installing and removing cap, and install gear lube monitor cap. Do not overtighten cap - 1/4 turn, after cap contacts seal, is sufficient.

⚠ CAUTION

On models with Gear Lube Monitor, that have a dipstick in driveshaft housing cover: **DO NOT REMOVE DIPSTICK - DO NOT CHECK OIL LEVEL WITH DIPSTICK.** Removal of dipstick results in oil level raising/overflow condition, which can cause oil seal damage; if left open, drive unit will overflow.

2. Check oil level in gear lube monitor.

Checking Lubricant for Water

Periodically inspect lubricant for water to ensure that drive unit seals are not leaking.

MODELS WITHOUT DRIVE UNIT GEAR LUBE MONITOR

1. Trim drive unit to the full Trim UP/OUT position.
2. Remove fill/drain plug to take a sample of lubricant. If water is observed or if lubricant appears discolored, drive unit is leaking and must be resealed.

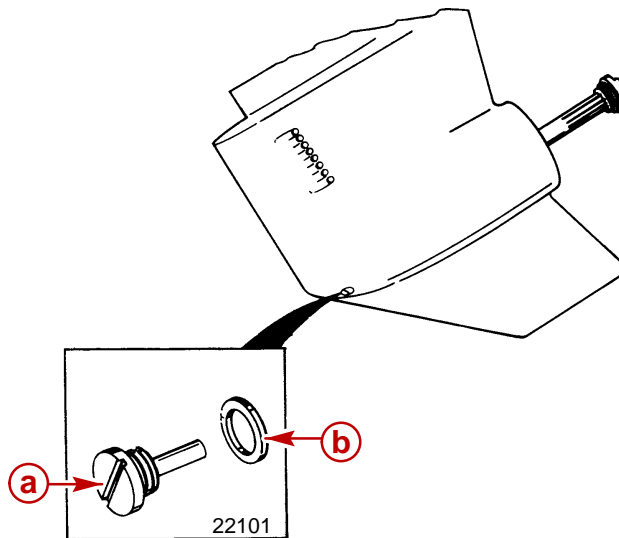

22103

- a** - Fill/Drain Plug
- b** - Sealing Washer Or O-ring

3. Reinstall fill/drain plug. Torque to 40 lb-in. (4.0 Nm).

MODELS WITH GEAR LUBE MONITOR

Check for water at bottom of gear lube monitor, and/or if oil appears discolored, a water leak is indicated somewhere in the drive unit, and drive unit must be resealed.

⚠ CAUTION

If more than 2 fl. oz. (59ml) of Quicksilver High Performance Gear Lube is required to fill gear lube monitor, a seal may be leaking. Find and correct cause of leak before unit is placed in operation.

IMPORTANT: If drive unit has set overnight or longer, check for water in drive unit, as follows:

1. Trim drive unit to full Trim UP/OUT position.

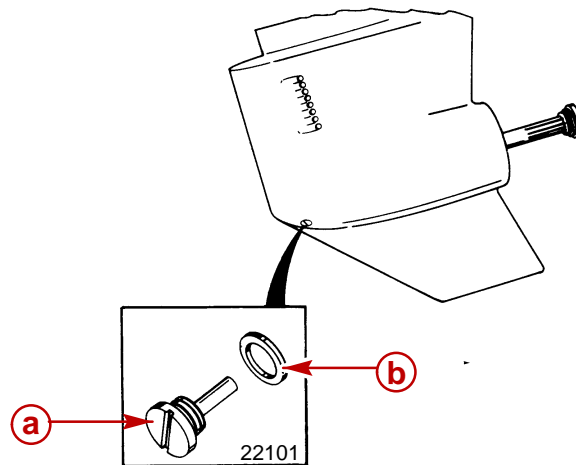

22103

- a** - Oil Fill/Drain Plug
- b** - Sealing Washer or O-ring

2. Remove fill/drain plug to sample lubricant. If water runs out, and/or if lubricant appears discolored, drive unit is leaking and **must** be resealed.
3. Reinstall fill/drain plug. Torque to 40 lb-in. (4 Nm).

Changing Lubricant

⚠ CAUTION

If any water drains from fill/drain hole, or if oil color appears discolored, a leak in drive unit may exist. Find and correct cause of leak before placing unit back in operation.

⚠ CAUTION

DO NOT attempt to fill drive unit through oil vent holes, as air will be trapped in drive unit and unit will be damaged from lack of lubrication.

1. Trim drive unit to full Trim UP/OUT position.

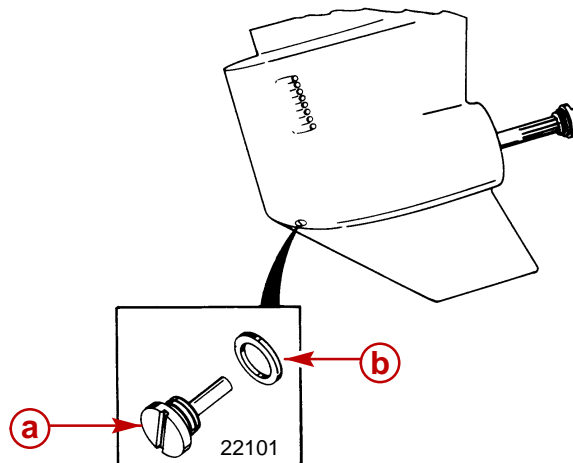

22103

- a** - Oil Fill/Drain Plug
- b** - Sealing Washer or O-ring

2. **Models with drive unit Gear Lube Monitor, only:** remove drive unit gear lube monitor from bracket, remove cap, empty contents of gear lube monitor into suitable container and discard. Clean gear lube monitor thoroughly, and return gear lube monitor to bracket. Do not refill at this time. Check condition of hose and hose connections - replace as necessary.

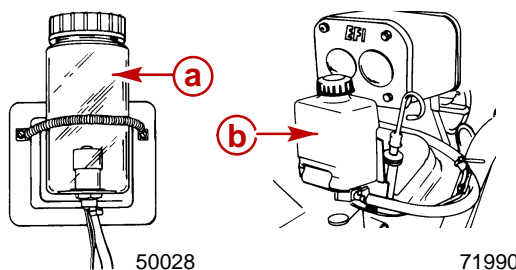

- a** - Round Gear Lube Monitor
- b** - Square Gear Lube Monitor

3. **All models:** remove drive unit vent plug, and fill/drain plug; allow lubricant to drain completely.



Download the full PDF manual instantly.

Our customer service e-mail:

aservicemanualpdf@yahoo.com